

|    |   |      |
|----|---|------|
| DE | <b>Serviceanleitung</b><br>Strahlreglerset inkl. Durchflussmengen-<br>begrenzer (5, 10, 15 l/min) für<br>KHS Hygienespülung PRO PURE LITE<br>Fig. 689 04 019                  | »» 2 |
| EN | <b>Service manual</b><br>Aerator set incl. Flow limiter<br>(5, 10, 15 l/min) for<br>KHS Hygiene Flush Box PRO PURE LITE<br>Fig. 689 04 019                                    | »» 3 |
| FR | <b>Instruction de service</b><br>Kit de régulateur du jet comprenant un<br>Limiteur de débit (5, 10, 15 l/min) pour<br>KHS Hygiene Flush Box PRO PURE LITE<br>Fig. 689 04 019 | »» 4 |
| IT | <b>Istruzioni di servizio</b><br>Set regolatore di getto incl. Limitatore di<br>flusso (5,10,15 l/min.) per<br>KHS Hygiene Flush Box PRO PURE LITE<br>Fig. 689 04 019         | »» 5 |
| NL | <b>Servicehandleiding</b><br>Straalregelaar-set incl. Flowbegrenzer<br>(5, 10, 15 l/min) voor<br>KHS Hygiene Flush Box PRO PURE LITE<br>Fig. 689 04 019                       | »» 6 |





### Herstelleradresse

Gebr. Kemper GmbH + Co. KG  
Harkortstraße 5  
57462 Olpe  
Tel.: +49 2761 891-0  
Web: www.kemper-group.com

### Kundendienst

Service-Hotline  
Tel.: +49 2761 891 800  
Mail: anwendungstechnik@kemper-group.com

### Über diese Anleitung

Lesen Sie diese Anleitung vor Montagebeginn oder Gebrauch sorgfältig und folgen Sie den Anweisungen! Bewahren Sie die Anleitung zur späteren Verfügung auf!

Abbildungen in dieser Anleitung dienen dem grundsätzlichen Verständnis und können von der tatsächlichen Ausführung abweichen.

### Haftung

Der Hersteller leistet keine Gewährleistung oder Haftung bei:

- Nichtbeachten dieser Anleitung.
- fehlerhaftem Einbau und/oder Gebrauch.
- eigenständiger Modifikation am Produkt.
- sonstiger, fehlerhafter Bedienung.

### Sicherheitshinweise

Beachten und befolgen Sie die Sicherheitshinweise in der Anleitung. Das Nichtbeachten der Sicherheitshinweise kann zum Tod, zu Verletzungen oder zu Sachschäden führen.

Kennzeichnung wichtiger Warnhinweise:



#### **Gefahr!** Elektrischer Strom!

Kennzeichnet Gefahren, die schwere oder tödliche Verletzungen zur Folge haben können.



#### **Warnung!**

Kennzeichnet Gefahren, die zu Verletzungen, Sachschäden oder Verunreinigung des Trinkwassers führen können.



#### **Hinweis!**

Kennzeichnet Gefahren, die zu Schäden an der Anlage oder Funktionsstörungen führen können.



#### **Gefahrenquellen**

##### **Gefahr!** Elektrischer Strom!

Lebensgefahr durch elektrischen Strom!

Schalten Sie das System vor Arbeiten daran spannungsfrei.



#### **Warnung!**

Verletzungsgefahr durch unsachgemäße Montage!

Die Montage und Wartung darf nur durch eine Sanitärfachkraft erfolgen.



#### **Warnung!**

Gesundheitsgefahr durch Rückstände in Leitungen!

- Spülen Sie die Leitungen nach Montage und Wartung immer nach DIN EN 806-5 und VDI/DVGW 6023 (siehe Seite 10).



### Manufacturer's address

Gebr. Kemper GmbH + Co. KG  
Harkortstraße 5  
57462 Olpe  
Tel.: +49 2761 891-0  
Web: www.kemper-group.com

### After-sales service

Service hotline  
Tel.: +49 2761 891 800  
Email: anwendungstechnik@kemper-group.com

### About this manual

Read this manual carefully before starting assembly, use and maintenance and follow the instructions! Retain the manual for later reference! Illustrations in this manual serve to aid basic understanding and may differ from the actual system configuration.

### Liability

The manufacturer assumes no warranty or liability in case of:

- failure to follow these instructions
- incorrect installation and/or use
- unauthorised modification of the product
- other improper methods of operation.

### Safety instructions

Be sure to read and follow the safety instructions in this manual. Failure to follow the safety instructions can result in injury or even death and in damage to property.

Labelling of important warning information:



#### **Danger!** Electricity!

Indicates hazards that may result in severe or fatal injury. .



#### **Warning!**

Indicates hazards that may result in injury, damage to property or contamination of drinking water.



#### **Note!**

Indicates hazards that may result in damage to the Hygiene Flush Box or malfunctions.



#### **Source of danger**

#### **Danger!** Electricity!

Danger of fatal electric shock!  
Disconnect the system before carrying out work on it.



#### **Warning!**

Risk of injury due to improper installation!  
Assembly and maintenance may only be carried out by a plumbing specialist.



#### **Warning!**

Health hazard from residues in feed pipes!

- Always flush the feed pipes in accordance with EN 806-5 and VDI/DVGW 6023 after assembly and maintenance work (see page 10).

**Adresse du fabricant**

Gebr. Kemper GmbH + Co. KG  
 Harkortsstraße 5  
 57462 Olpe  
 Tél.: +49 2761 891-0  
 Site Internet: www.kemper-group.com

**Service après-vente**

Ligne d'assistance téléphonique du service après-vente  
 Tél.: +49 2761 891 800  
 E-mail: anwendungstechnik@kemper-group.com

**A propos de cette notice**

Lisez soigneusement la notice avant le montage ou l'utilisation et respectez les instructions! Conservez la notice comme référence à l'avenir!  
 Les illustrations de cette notice ont pour but de donner au lecteur une compréhension de base et peuvent diverger du modèle existant.

**Responsabilité**

Le fabricant n'assume aucune responsabilité ni aucune garantie:

- en cas de non-respect de cette notice,
- en cas d'installation et/ou d'utilisation incorrecte(s),
- en cas de modification autonome du produit et
- en cas de toute autre utilisation inappropriée.

**Consignes de sécurité**

Tenez compte et respectez impérativement les consignes de sécurité indiquées dans cette notice. Le non-respect des consignes de sécurité peut entraîner la mort, des blessures ou des dommages matériels.

Marquage des avertissements importants:



**Danger! Courant électrique!**  
 Indique les dangers pouvant entraîner la mort ou des blessures graves.



**Avertissement!**  
 Indique les dangers pouvant entraîner des blessures, des dégâts matériels ou une contamination de l'eau potable.



**Remarque!**  
 Indique les dangers pouvant entraîner des détériorations sur le KHS Hygiene Flush Box ou des dysfonctionnements.



**Sources de danger**  
**Danger! Courant électrique!**  
 Danger de mort dû au courant électrique!  
 Mettez systématiquement le système hors tension avant tous travaux à effectuer dessus.



**Avertissement!**  
 Risque de blessures en cas de montage incorrect!  
 Uniquement un spécialiste en sanitaire est autorisé à effectuer le montage et l'entretien.



**Avertissement!**  
 Risque pour la santé dû aux résidus se trouvant dans les conduites!

- Rincez systématiquement les conduites après le montage et la maintenance conformément aux normes DIN EN 806-5 et VDI/DVGW 6023 (voir page 10).

### Indirizzo del produttore

Gebr. Kemper GmbH + Co. KG  
Harkortstraße 5  
57462 Olpe  
Tel.: +49 2761 891-0  
Web: www.kemper-group.com

### Servizio clienti

Service-Hotline  
Tel.: +49 2761 891 800  
E-mail: anwendungstechnik@kemper-group.com

### Informazioni su queste istruzioni

Leggere con attenzione le presenti istruzioni prima di procedere al montaggio e all'utilizzo. Attenersi alle indicazioni fornite! Conservare le istruzioni per poterle consultare in seguito!

Le immagini riportate in queste istruzioni hanno lo scopo di agevolare la comprensione di base e possono differire dall'effettiva versione dell'impianto.

### Responsabilità

Il produttore non fornisce alcuna garanzia né si assume alcuna responsabilità in caso di:

- mancata osservanza delle presenti istruzioni
- installazione e/o utilizzo errato
- modifica arbitraria del prodotto
- altro impiego non conforme.

### Avvertenze di sicurezza

Rispettare e seguire scrupolosamente le avvertenze di sicurezza riportate in queste istruzioni. La mancata osservanza delle avvertenze di sicurezza può essere causa di morte, lesioni o danni materiali.



Indicatori delle avvertenze importanti:



**Pericolo!** Corrente elettrica!  
Indica i pericoli che possono avere come conseguenza lesioni gravi o mortali.



**Attenzione!**  
Indica i pericoli che possono essere causa di lesioni, danni materiali o inquinamento dell'acqua potabile.



**Nota!**  
Indica i pericoli che possono causare danni all'impianto o malfunzionamenti.



### Fonti di pericolo

**Pericolo!** Corrente elettrica!  
Pericolo di morte per scossa elettrica!  
Prima di qualunque intervento, scollegare il sistema dall'alimentazione elettrica



**Attenzione!**  
Pericolo di lesioni per montaggio non corretto!  
Montaggio e manutenzione devono essere eseguiti esclusivamente da personale specializzato in impianti sanitari.



**Attenzione!**  
Rischi per la salute derivanti da depositi presenti nei condotti!

- Dopo gli interventi di montaggio e manutenzione sciacquare sempre i condotti conformemente alle norme DIN EN 806-5 e VDI/DVGW 6023 (vedi pagina 10).

» 7

**Adres van de fabrikant**

Gebr. Kemper GmbH + Co. KG  
Harkortstraße 5  
57462 Olpe  
Tel.: +49 2761 891-0  
Web: www.kemper-group.com

**Technische dienst**

Service hotline  
Tel.: +49 2761 891 800  
Mail: anwendungstechnik@kemper-group.com

**Over deze handleiding**

Lees deze handleiding zorgvuldig door voordat u begint met de installatie en het gebruik en volg de instructies op! Bewaar deze handleiding goed, zodat u haar later weer kunt raadplegen! Afbeeldingen in deze handleiding dienen voor het begrip van de werking en kunnen afwijken van de daadwerkelijke uitvoering.

**Aansprakelijkheid**

De fabrikant verleent geen garantie en stelt zich niet aansprakelijk bij:

- het negeren van deze handleiding
- incorrecte inbouw en/of incorrect gebruik
- eigenmachtige wijziging van het product
- andere foutieve bediening.

**Veiligheidsinstructies**

Neem de veiligheidsinstructies in de handleiding in acht en volg ze op. Het niet in acht nemen van de veiligheid-sinstructies kan leiden tot de dood, letsel of materiële schade.



Markering belangrijke waarschuwingen:



**Gevaar! Elektrische stroom!**  
Markeert gevaren die ernstig of dodelijk letsel tot gevolg kunnen hebben.



**Waarschuwing!**  
Markeert gevaren die tot letsel, materiële schade of verontreiniging van het drinkwater kunnen leiden.



**Aanwijzing!**  
Markeert gevaren die tot schade aan de hygiënespoeler of tot functiestorings kunnen leiden.



**Gevarenbronnen**  
**Gevaar! Elektrische stroom!**  
Levensgevaar door elektrische stroom!  
Schakel het systeem voor werkzaamheden eraan spanningsvrij.



**Waarschuwing!**  
Letselgevaar door onvakkundige montage!  
Montage mogen alleen door een loodgieter worden uitgevoerd.



**Waarschuwing!**  
Gevaar voor de gezondheid door residuen in leidingen!  
Spoel de leidingen na montage en onderhoud altijd door volgens EN 806-5 en VDI/DVGW 6023 (zie pagina 10).



Durchflussmengenbegrenzer tauschen · Flow Limiter replacement ·  
Remplacer le limiteur de débit · Sostituzione limitatore di flusso ·  
Flowbegrenzer vervangen

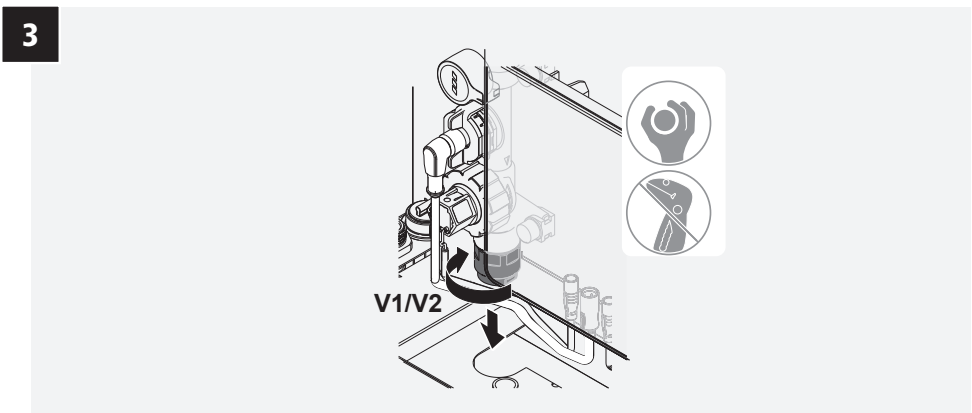
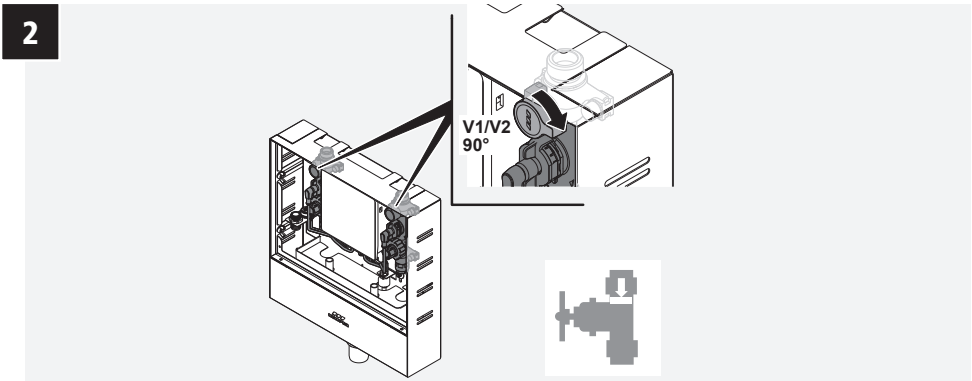
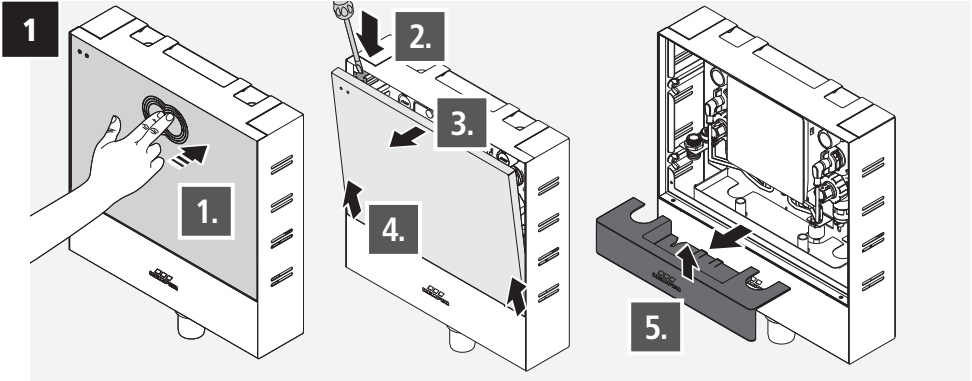

4

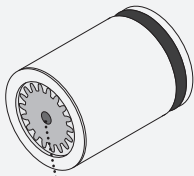
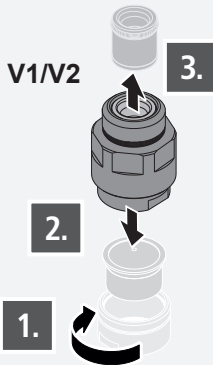

- DE** Prüfen, welcher Durchflussmengenbegrenzer (DMB) eingebaut war oder verbaut werden soll.
- EN** Check which flow limiter was installed / shall be installed.
- FR** Vérifiez quel limiteur de débit (DMB) a été installé ou doit être installé.
- IT** Verificare quale limitatore di flusso (DMB) è stato installato ho deve essere installato.
- NL** Controleren welke flowbegrenzer (DMB) ingebouwd was of moet worden ingebouwd.

| DMB      | Farbe   | Colour | Couleur | Colore | Kleur |
|----------|---------|--------|---------|--------|-------|
| 5 l/min  | Schwarz | Black  | Noir    | Nero   | Zwart |
| 10 l/min | Rot     | Red    | Rouge   | Rosso  | Rood  |
| 15 l/min | Blau    | Blue   | Bleu    | Blu    | Blauw |

5



- DE Hinweis!** Bei einem Austausch eines Strahlreglersets, sind die kompletten Komponenten auszutauschen.
- EN Note!** Replace all components during exchange of an aerator set.
- FR Remarque!** Lors du remplacement d'un kit régulateur de jet, les composants complets doivent être remplacés.
- IT Nota!** Quando si sostituisce un set regolatore del getto, sono da sostituire tutti i componenti.
- NL Aanwijzing!** Bij vervanging van de straalregelaar-set, moeten alle componenten vervangen worden.



6

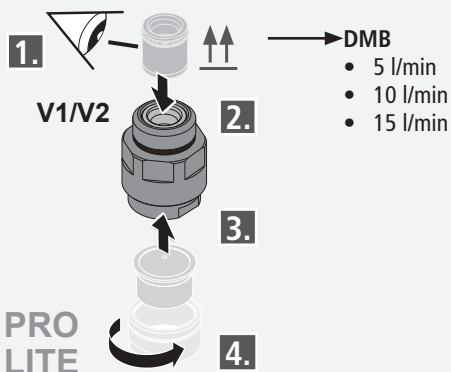

**DE Hinweis!** Sollte ein DMB mit anderer Durchflussmenge als der werksseitig vormontierte DMB eingebaut werden, muss dies bei der Inbetriebnahme / den Betriebsarten angepasst werden!

**NE Note!** Should a flow limiter with a different flow rate than the factory pre-assembled flow limiter be installed, this must be changed in the operating modes of the.

**FR Remarque!** Si une taille différente de limiteur de débit (DMB) doit être installée, celle-ci doit être adaptée lors de la mise en service / aux modes de fonctionnement.

**IT Nota!** Se è necessario installare un limitatore di flusso (DMB) di dimensioni diverse, questo deve essere adattato durante la messa in servizio nelle modalità operative.

**NL Aanwijzing!** Als een andere afmeting van de flowbegrenzer moet worden geïnstalleerd, moet deze tijdens de inbedrijfstelling in de bedrijfsmodus worden aangepast.

7

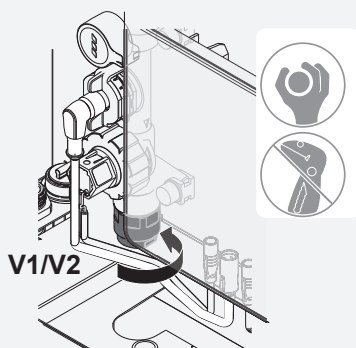

8

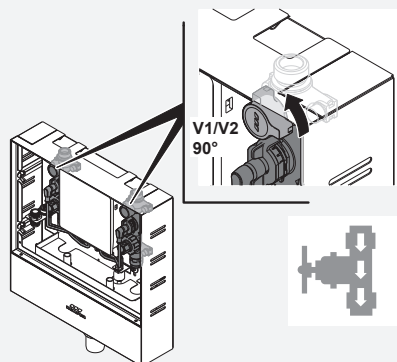



## Handspülung · Manual flushing · Rinçage manuel · Risciacquo manuale · Handmatige spoeling

9

PRO

10 s or 

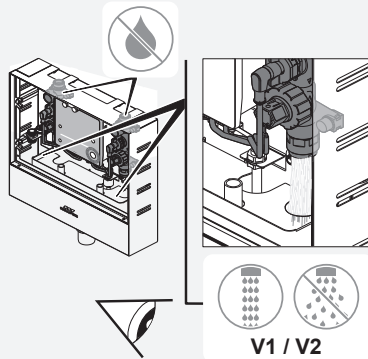
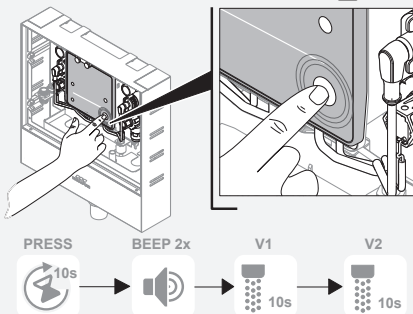

PURE

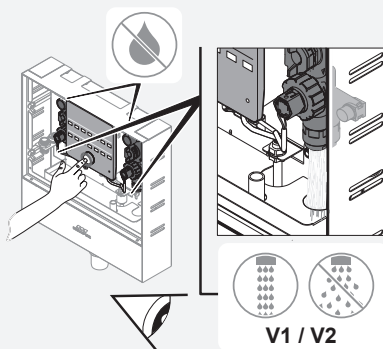
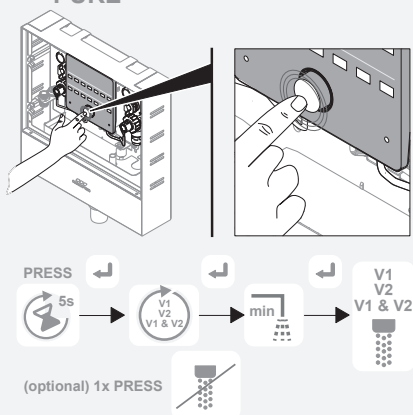

LITE

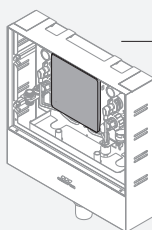

- 1 min. Handspülung über GLT/ BMS ausführen
- perform 1 min manual flushing vis BMS
- effectuez le rinçage hygiénique pendant 1 min via GTS/BMS
- eseguire 1 min di risciacquo manuale tramite BMS
- 1 min handmatige spoeling via BS/BMS uitvoeren

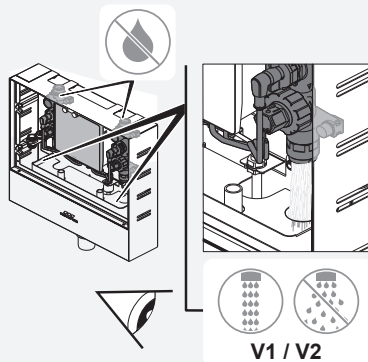

10



- DE Sollte, während der zuvor ausgeführten Handspülung, kein sauberer Sprühkegel oder sogar kein Wasser aus dem Strahlregler, austreten, so ist die Störtabelle aus der **Einbau- und Bedienungsanleitung - Bauteil Strahlregler-set (DMB/RV)** - zu sichten - Seite 89.
- EN If no water comes out of the aerator or the spray-pattern is not good during the previously described manual flush, check the troubleshooting chart in the **manual „component aerator set/ (FL/CV)“** on page 93.
- FR Si, lors du rinçage manuel effectué précédemment, aucun cône de pulvérisation propre ou même aucune eau ne sort de l'aérateur, veuillez vous référer au tableau des dysfonctionnements dans les **instructions d'installation et d'utilisation - Kit de régulateur de jet (Limiteur de débit/Clapet anti-retour)** - doit être consulté - page 97.
- IT Se durante il risciacquo manuale eseguito in precedenza dall'aeratore non fuoriesce alcun cono di nebulizzazione pulito o anche acqua, è necessario consultare la tabella dei guasti delle **istruzioni di montaggio de d'uso Kit aeratore componente (limitatore di flusso/ blocca-riflusso)** - pagina 101.
- NL Indien er tijdens de uitgevoerde handmatige spoeling geen heldere waterstraal of helemaal geen water uit de straalregelaar stroomt, moet de storingstabel in de **inbouw- en bedieningshandleiding - onderdeel Straalregelaar-set (flowbegrenzer/keerklep)** - geraadpleegd worden. Pagina 105.



11

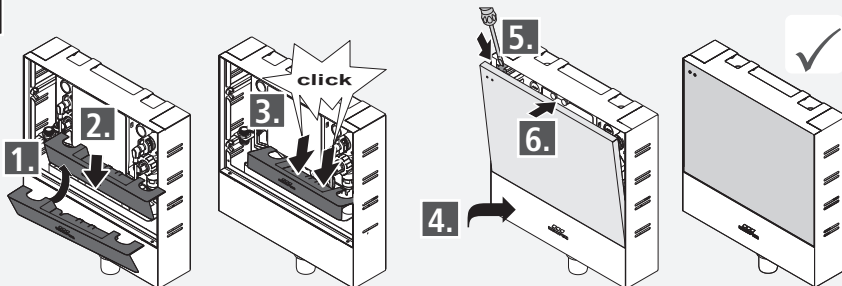

  
FORTSCHRITT MACHEN

**Gebr. Kemper GmbH + Co. KG**  
Harkortstraße 5  
D-57462 Olpe



Service-Hotline +49 2761 891-800  
[www.kemper-group.com](http://www.kemper-group.com)  
[info@kemper-group.com](mailto:info@kemper-group.com)

K410068903009-00 / 03.2023