

DE	<b>Montage- und Bedienungsanleitung</b> KHS CoolFlow Kaltwasser-Regulierventil Fig. 615 2G   616 2G   617 0G	» 2
EN	<b>Operating instructions</b> KHS CoolFlow Cold water regulating valve Fig. 615 2G   616 2G   617 0G	» 21
FR	<b>Manuel d'utilisation</b> KHS CoolFlow Robinet de régulation d'eau froide Fig. 615 2G   616 2G   617 0G	» 41
IT	<b>Istruzioni per l'uso</b> KHS CoolFlow Valvola di regolazione dell'acqua fredda Fig. 615 2G   616 2G   617 0G	» 61
NL	<b>Bedieningshandleiding</b> KHS CoolFlow Koudwater-inregelafsluiter Fig. 615 2G   616 2G   617 0G	» 81

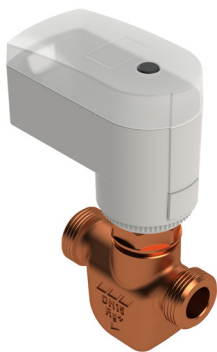

Fig. 615 2G



Fig. 616 2G



Fig. 615 0G | 616 0G | 617 0G

**Hinweis!**

Scannen Sie den QR-Code, um für diese Produktvarianten eine entsprechende Anleitung zu erhalten.

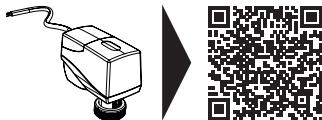

[https://www.kemper-group.com/media/crossbase/dok\\_anl\\_k410061500001-00\\_sall\\_ain\\_v106.pdf](https://www.kemper-group.com/media/crossbase/dok_anl_k410061500001-00_sall_ain_v106.pdf)

**Zulassungen**

ÜA



WRAS

**Inhaltsverzeichnis**

Sicherheitshinweise	3
1 Technische Daten	4
2 Aufbau und Funktion	6
3 Einstellung	7
4 Montage	9
5 Elektrischer Anschluss	11
6 Funktionsanzeigen	16
7 Per Hand absperren	18
8 Instandhaltung	19
9 Demontage und Entsorgung	20
10 Ersatzteile und Zubehör	20

**Herstelleradresse**

Gebr. Kemper GmbH + Co. KG  
Harkortstraße 5  
57462 Olpe  
Tel.: +49 2761 891-0  
Web: [www.kemper-group.com](http://www.kemper-group.com)

**Kundendienst**

Service-Hotline  
Tel.: +49 2761 891 800  
Mail: [anwendungstechnik@kemper-group.com](mailto:anwendungstechnik@kemper-group.com)

**Über diese Anleitung**

Lesen Sie diese Anleitung vor Montagebeginn oder Gebrauch sorgfältig und folgen Sie den Anweisungen! Bewahren Sie die Anleitung zur späteren Verfügung auf!

Abbildungen in dieser Anleitung dienen dem grundsätzlichen Verständnis und können von der tatsächlichen Ausführung abweichen.

**Haftung**

Der Hersteller leistet keine Gewährleistung oder Haftung bei:

- Nichtbeachten dieser Anleitung.
- fehlerhaftem Einbau und/oder Gebrauch.
- eigenständiger Modifikation am Produkt.
- sonstiger, fehlerhafter Bedienung.

**Bestimmungsgemäße Verwendung**

Das KHS CoolFlow Kaltwasser-Regulierventil (im Folgenden „Ventil“) reguliert, spült und sperrt Trinkwasser-Zirkulationskreise in Installationen mit KHS-Hygiensystem. Jede andere Verwendung gilt als nicht bestimmungsgemäß.

**Fehlgebrauch**

Verwenden Sie das Ventil nicht für die Zirkulation von anderen Stoffen als Trinkwasser und nur innerhalb der in den technischen Daten angegebenen Einsatzgrenzen.



## Sicherheitshinweise

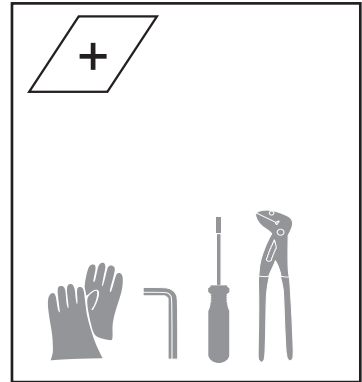
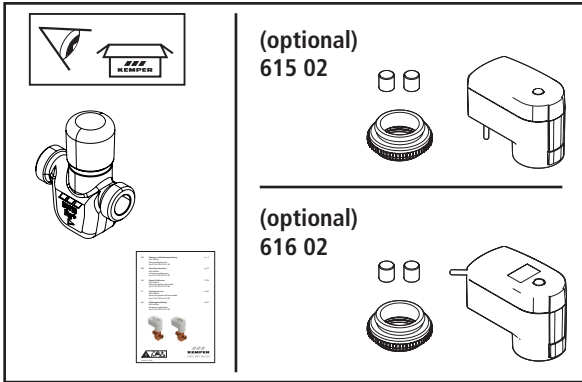

### Sicherheitshinweise

Beachten und befolgen Sie die Sicherheitshinweise in der Anleitung. Das Nichtbeachten der Sicherheitshinweise kann zum Tod, zu Verletzungen oder zu Sachschäden führen.

Kennzeichnung wichtiger Warnhinweise:



#### **Gefahr!** Elektrischer Strom!

Kennzeichnet Gefahren, die schwere oder tödliche Verletzungen zur Folge haben können.



#### **Warnung!**

Kennzeichnet Gefahren, die zu Verletzungen, Sachschäden oder Verunreinigung des Trinkwassers führen können.



#### **Hinweis!**

Kennzeichnet Gefahren, die zu Schäden an der Anlage oder Funktionsstörungen führen können.

### Gefahrenquellen



#### **Gefahr!** Elektrischer Strom!

Lebensgefahr durch elektrischen Strom! Schalten Sie das System vor Arbeiten daran spannungsfrei.



#### **Warnung!**

Verletzungsgefahr durch unsachgemäße Montage!

Die Montage und Wartung darf nur durch eine Sanitärfachkraft erfolgen.



#### **Warnung!**

Gesundheitsgefahr durch Rückstände in Leitungen!

Spülen Sie die Leitungen nach Montage und Wartung immer nach DIN EN 806-5 und VDI/DVGW 6023 (siehe Kapitel 7 Abbildung 1-2).



#### **Hinweis!**

Sachschäden durch zu hohe Temperaturen bei thermischer Desinfektion! Demontieren Sie das Regulierventil bei thermischer Desinfektion und setzen Sie ein Passstück ein.

Bei Montage beachten:  
DIN EN 806 | DIN EN 1717 | DIN 1988

	Figur-Nr.	Produktvariante	Funktion
	615 2G	Mit Stellantrieb 230 V	Für Master/Slave-System
	616 2G	Mit Stellantrieb 24 V	Für GLT mit Stellungsrückmeldung
	617 0G	Ohne Stellantrieb	Keine Spülfunktion

Regulierventil	Wert	Einheit
Einstellbereich	15 bis 22	°C
Druckstufe	10	PN
Max. Betriebstemperatur Medium	50	°C
Kv-Min - siehe Kapitel 3	0,03	m³/h
Kv-Max - siehe Kapitel 3	1,72	m³/h
Kv-Spül (nur mit Stellantrieb) - siehe Kapitel 3	2,2	m³/h
Nennweite Anschlüsse	15	DN
Abmessungen (H x L x B, mit Stellantrieb)	156,5 x 90 x 45	mm
Abmessungen (H x L x B, ohne Stellantrieb)	91,5 x 73 x 31	mm

## 1

## Technische Daten

Stellantrieb	Fig. 615 2G (230 V)	Fig. 616 2G (24 V)	
Spannungsversorgung	230 V AC (50 Hz)	24 V AC (50/60 Hz)	24 V DC
Leistungsaufnahme Dimensionierung	5,8 VA	4,4 VA	1,9 W
Leistungsaufnahme nominal	3,5 VA	2,0 VA	1,0 W
Max. Einschaltstrom	kurzzeitig max. 10 A		
Anschlusskabellänge	1,0 m		
Kabelquerschnitt	3 x 0,75 mm <sup>2</sup>	4 x 0,22 mm <sup>2</sup>	
Max. Umgebungstemperatur	50 °C		
Max. Umgebungsfeuchte	0 - 85 % (nicht kondensierend)		
Überspannungskategorie	II	III	
Stellkraft	200 N		
Verschmutzungsgrad	2		
Schutzklasse nach EN 60730	2	3	
Max. Ventilhub	8,5 mm (Fehlermeldung und Stell- fahrten über LED Farben ablesbar)	8,5 mm (Position und anliegende Steuerspannung ablesbar)	
Stellzeit	15 s/mm		
Anzeige	LED mehrfarbig	LED mehrfarbig & LCD	

**Hinweis!**

Die minimale Taktzeit im 3-Punktbetrieb beträgt  $\geq 2$  Sekunden.  
Wird der Antrieb mit einer kürzeren Einschaltzeit getaktet, ist eine korrekte Abschaltung nicht gewährleistet.

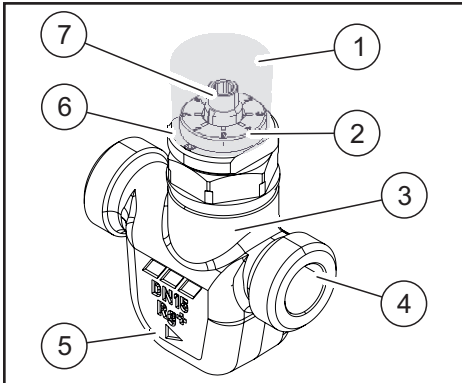

- |   |                                       |
|---|---------------------------------------|
| 1 | Schutzkappe                           |
| 2 | Stellungsanzeige                      |
| 3 | Gehäuse Ventil                        |
| 4 | Rohranschlüsse                        |
| 5 | Anzeige Fließrichtung                 |
| 6 | Motorhalterung/ Temperaturverstellung |
| 7 | Spindel                               |
| 8 | Regulierkegel                         |

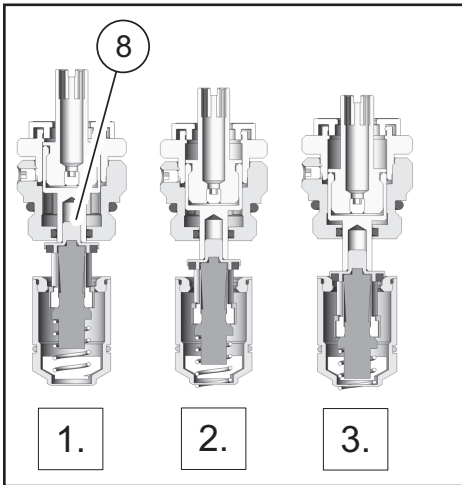

### Funktion

Die Stellung des Ventils bestimmt die Funktion.

1. **Regulierfunktion:** Die thermische Regulierfunktion sorgt für einen automatischen hydraulischen Abgleich des Kaltwasser-Zirkulationssystems.
2. **Spülfunktion:** Die Spülfunktion ermöglicht eine turbulente Durchströmung in allen Bereichen der Trinkwasser-Installation.
3. **Absperrfunktion:** Die elektrische Absperrfunktion dient dem Absperrn aller Kaltwasser-Regulierventile die verbaut wurden. Während eines Spülvorganges werden alle Kaltwasser-Regulierventile bis auf das spülrelevante abgesperrt. An dem spülrelevanten Kaltwasser-Regulierventil kann nun die Spülfunktion (2.) durchgeführt werden. Von zentraler Stelle aus kann das System wie beschrieben abgesperrt werden, um den Spülprozess nacheinander durchzuführen.

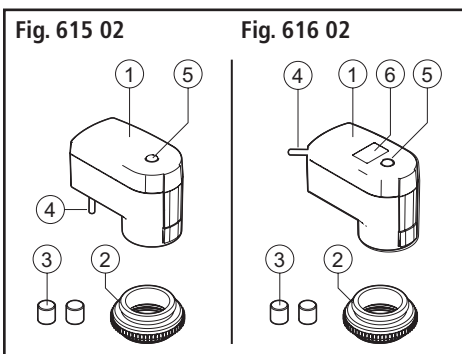

### Stellantrieb

Der Stellantrieb ermöglicht die Spülfunktion.

- |   |  |
|---|--|
| 1 | Gehäuse Stellantrieb                               |
| 2 | Ventiladapter VA 80 – M30 x 1,5 8,5 mm             |
| 3 | Verlängerungskappe (1x als Ersatz im Lieferumfang) |
| 4 | Anschlusskabel                                     |
| 5 | LED Anzeige  |
| 6 | LC-Display mit Statusanzeige                       |

## 2

## Aufbau und Funktion

### Einsatzumgebung

Das Regulierventil ist für den Einsatz in Trinkwasser-Installationen mit dem Hygienesystem KHS CoolFlow vorgesehen. Es ist einsetzbar in neuen KHS-Anlagen und ist nachrüstbar in bestehende

KHS-Anlagen. Eine Einbindung in bestehende Hygienesysteme ist durch Ansteuerung über Master/Slave oder GLT möglich.

## 3

## Einstellung

1

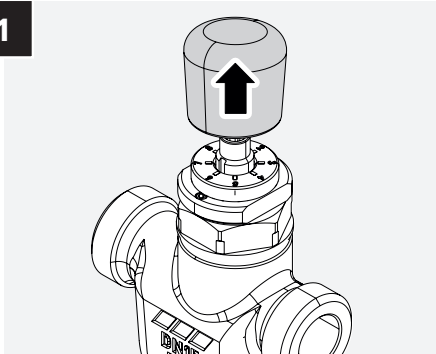

2

Lösen

Hinweis! Werks-  
einstellung 3!

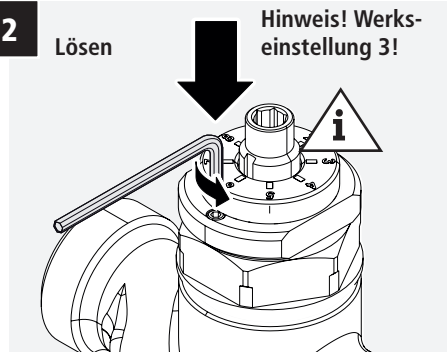

3

S. 8 Regelbereiche

Stellungsanzeige

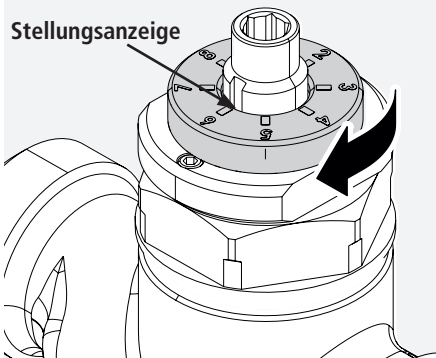

4

Fixieren

Hinweis! Spindel  
nach links in den  
Anschlag drehen!

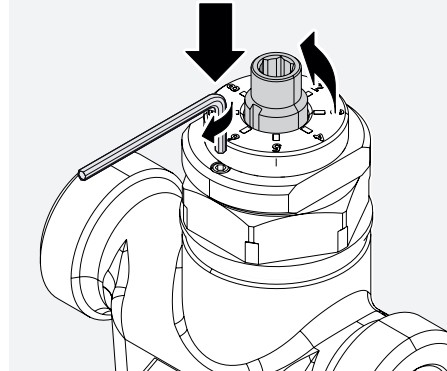

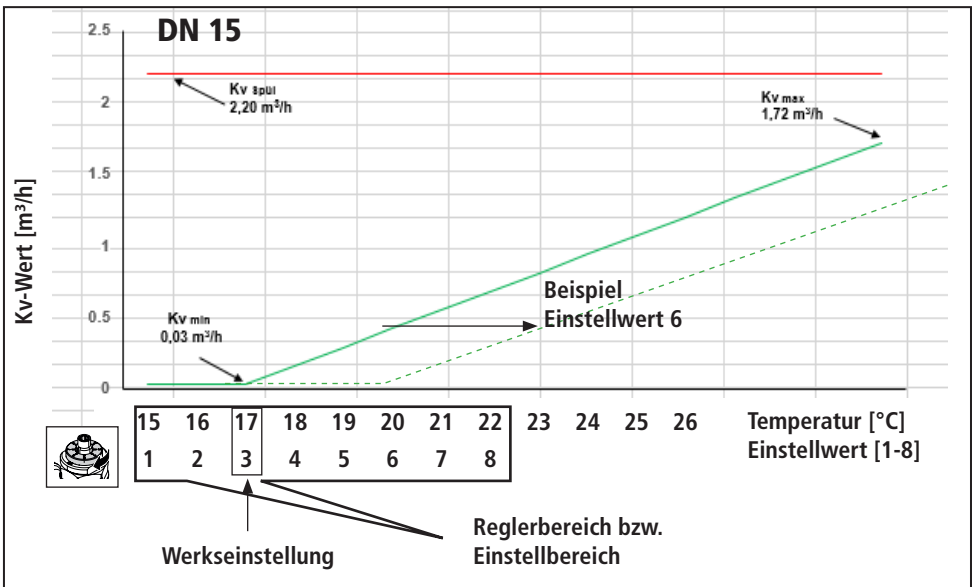
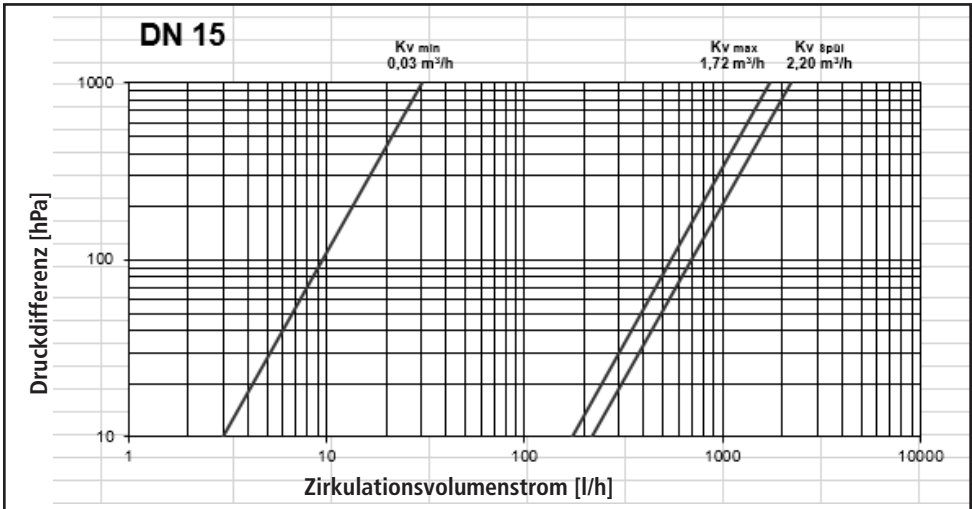

# 4

## Montage

1

Hinweis!  
Störmaße einhalten!

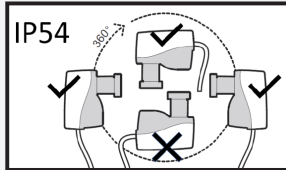

96 mm

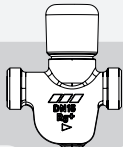

113 mm



70 mm

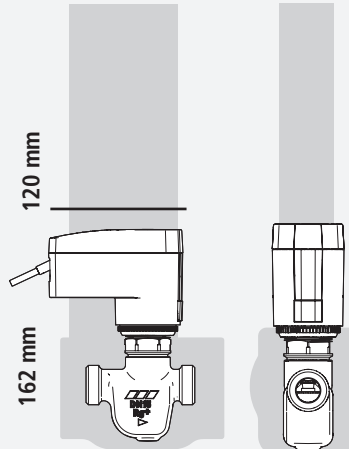

113 mm

70 mm

2

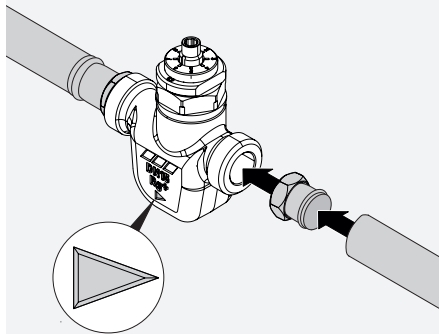

Hinweis!  
Fließrichtung beachten!  
In geraden Rohrstrang  
einsetzen!

3



Hinweis!  
Die nachfolgenden  
Arbeitsschritte gelten für  
die Ausführungen 615 2G  
und 616 2G.

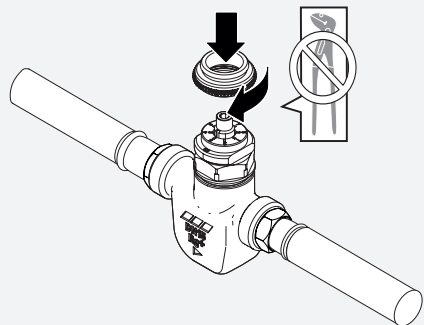

4

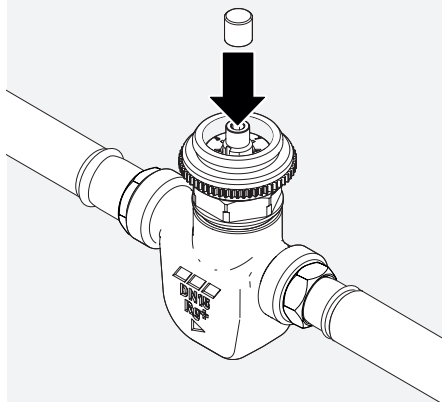

**Hinweis!**  
Eine Verlängerungskappe ist  
als Ersatz im Lieferumfang  
vorhanden.

5

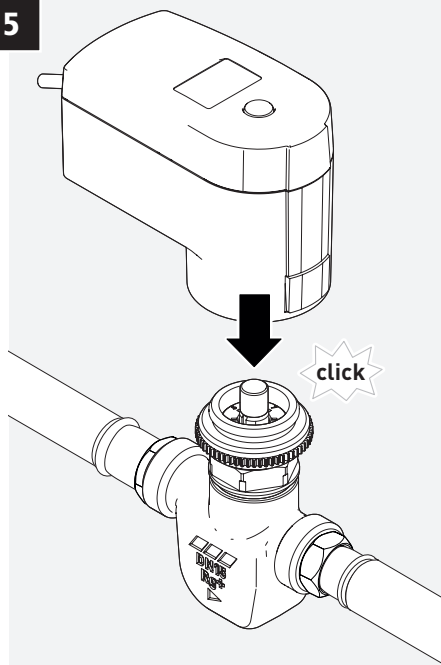

6

Fig. 615 2G (24 V Ausführung)

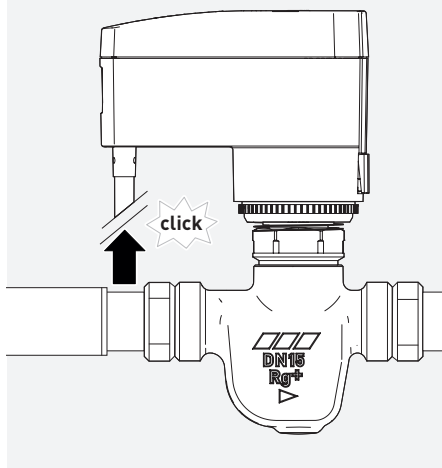

7

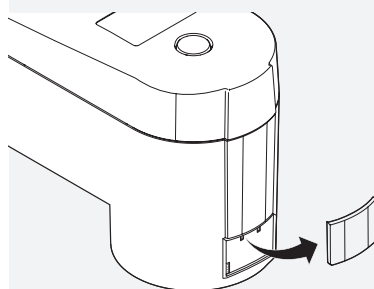

**Hinweis!**  
Das Entfernen der  
Verriegelungstaste schützt  
vor Demontage durch  
Unbefugte.

# 5

## Elektrischer Anschluss 230 V

1



**Gefahr!**  
Elektrischer Strom! Umgebung trocken halten!  
Vor Öffnen des Gehäuses spannungsfrei schalten!



**Hinweis!**  
Die Fig. 615 2G und die Fig. 615 02 können nur mit der MASTER 2.1 Gerätesoftware größer V2.23.15 angelernt werden. Zudem muss der entsprechenden Ventiltyp „KHS CoolFlow V2.0“ konfiguriert werden!



➔ Anschluss 230V:  
Fig. 686 02 008

[1] → br (BN)  
[2] → sw (SW)  
[3] → gr (GR)

**Hinweis!**  
Anschluss 230 V nur in Verbindung mit KHS Mini-Systemsteuerung MASTER 2.1 bzw. KHS Mini-Systemsteuerung SLAVE.



**Hinweis!**  
Bauseits ist für eine ausreichende Entstörung der Zuleitung zum Antrieb zu sorgen.

Die Ansteuerung des 230V 3 Punkt Stellantriebs erfolgt über die KHS Mini-Systemsteuerung MASTER 2.1. Für die Installation einer 230 V-Anlage werden folgende Leitungen empfohlen:

- Mantelleitung: NYM 5x1,5mm<sup>2</sup>
- Stegleitung: NYIF 5x1,5mm<sup>2</sup>

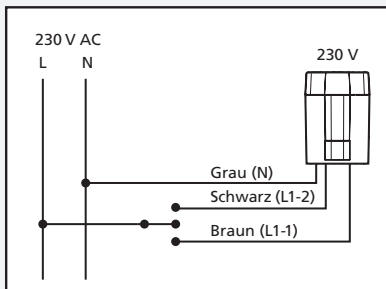

Funktion	Beschreibung
Grau (N)	Neutralleiter
Spannung an Schwarz (L1-2)	Ventildruckplatte fährt ein
Spannung an Braun (L1-2)	Ventildruckplatte fährt aus
Keine Spannung an Braun und Schwarz	Ventildruckplatte verharrt an aktueller Position

## 1

**Initialisierung:**

Nach dem Einschalten der Spannungsversorgung führt das KHS CoolFlow Kaltwasser-Regulier-ventil Fig. 616 2G proportional eine Initialisierung durch. In der Initialisierungsphase ermittelt der Stellantrieb den Verfahrweg und zeigt dabei im Display „In“ (für Initialisierung) an. Gleichzeitig blinkt die grüne LED.

Zuerst wird die Ventildruckplatte komplett eingefahren, wodurch der innere Endanschlag des Antriebs ermittelt wird.

Im Anschluss fährt die Ventildruckplatte aus und ermittelt auf dem Weg zuerst die Position der Berührung mit dem Ventilstößel und den zweiten Endanschlag, wenn das Ende des Ventilwegs erreicht wird und der Stellmotor zum Stillstand gekommen ist.

Das Ende der Initialisierung wird dadurch angezeigt, dass die grüne LED erlischt, „In“ im Display erlischt und die wechselnde Anzeige der anliegenden Steuerspannung und der aktuellen Stellposition erscheint.

**Hinweis!**

Für eine Initialisierungsphase benötigt das KHS CoolFlow Kaltwasser-Regulierventil Fig. 616 2G proportional max. 7 min. Während der Initialisierung reagiert der Stellantrieb nicht auf die anliegende Steuerspannung.

**Betrieb**

Die Ansteuerung des 24 V Stellantrieb erfolgt über ein 0 – 10 VDC-Steuersignal durch die Gebäudeleittechnik. Das Steuersignal ermöglicht eine präzise Ansteuerung und Positionierung des Stellantriebs. Alternativ kann auch ein PWM-Signal am Steuerspannungseingang angelegt werden, siehe Diagramm:

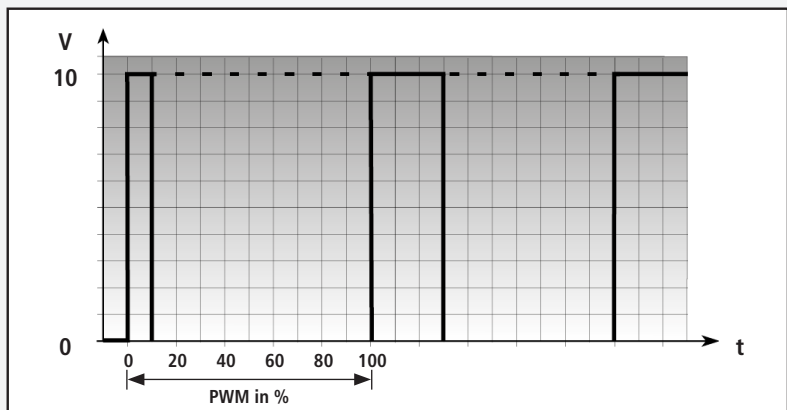

### Pulsweitenfrequenz 100 Hz bis 1000 Hz

Nach Initialisierung wird die anliegende Steuerspannung proportional in eine Stellposition umgesetzt. Der Antrieb errechnet aus Steuerspannung, dem eingestellten Stellweg oder dem gemessenen Verfahrweg (je nach Modus) die anzufahrende Stellposition und fährt diese präzise an.



#### Hinweis!

- 0 V ist kompletter Ventilstößel ausgefahren
- 4,6 V Ventilstößel in Spülstellung
- 10 V ist kompletter Ventilstößel eingefahren

#### Ansteuerung CoolFlow 24 V Stellantrieb

Funktion	Spannung	Beschreibung
1 Regulierfunktion	10 V	Ventil regulieren
2 Spülfunktion	4,6 V	Ventil spült (+/- 0,5 V Kv-Spül)
3 Absperrfunktion	0 V	Ventil geschlossen

## 2

**Feedback-Signal**

Das Feedback-Signal des 24 V Stellantrieb ermöglicht über ein 0 bis 10 V-Signal eine direkte Rückmeldung des aktuellen Betriebszustandes an die DDC-Anlage. Spannungen von 1 bis 9 Volt geben Aufschluss über die Antriebsposition, Spannungen  $< 0,5$  V und  $> 9,5$  V signalisieren aufgetretene Fehler. Der Anschluss des Feedback-Signals ist bis 24 V spannungsfest.

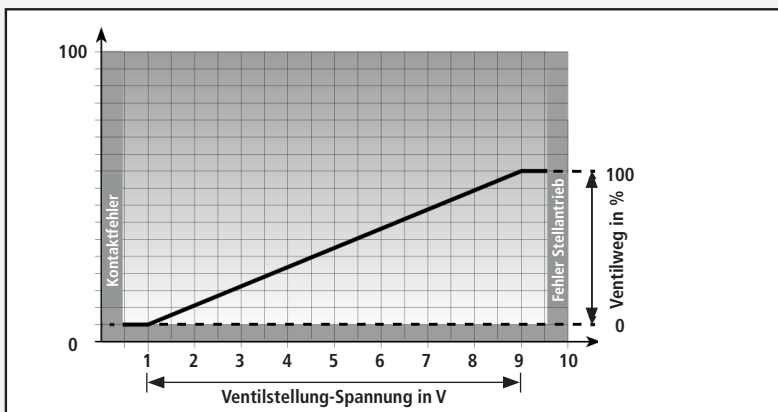

## Elektrischer Anschluss 24 V Stellantrieb AC/DC L1 (+) L2 (-)

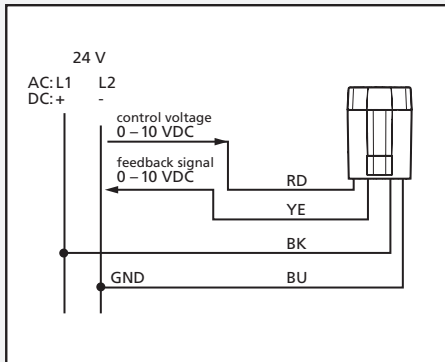
**Anschlussleitung**

Für die Installation einer 24 V-Anlage werden folgende maximale Leitungslängen empfohlen:

Leitung	Querschnitt	Länge
Standard-DCC-Leitung	0,22 mm <sup>2</sup>	20 m
J-Y(ST)Y	0,8 mm <sup>2</sup>	45 m
NYM / NYIF	1,5 mm <sup>2</sup>	136 m

**Transformator/Netzteil**

Es ist grundsätzlich ein Sicherheitstransformator nach EN 61558-2-6 oder ein Schaltnetzteil nach EN 61558-2-16 zu verwenden.

### Funktionsanzeigen über LED

Für die Funktionssignalisierung von Betriebszuständen, verfügt der Motoric Valve Drive: 230 V 3-Point über eine mehrfarbige LED. Als Signalfarben werden Grün, Orange und Rot verwendet. Eine Signalisierung erfolgt nur, wenn der Stellantrieb mit Betriebsspannung versorgt wird. Die LED leuchtet ca. 3 Sekunden nach dem Einschalten, um ein Blinken bei Impulsansteuerung zu verhindern.

Läuft der Antrieb gegen den oberen oder unteren Anschlag, schaltet der Motor nach einem Zeitüberlauf ab, ebenso die LED.

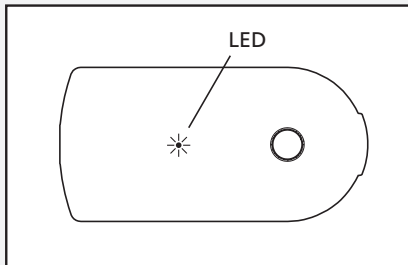

LED-Signal	Bedeutung
Rot	Fehlerfall
Grün	Ventildruckplatte fährt ein
Orange	Ventildruckplatte fährt aus

### LCD-Display | gilt nur für Fig. 616 2G

Das LCD-Display des 24 V Stellantrieb zeigt im Wechsel die Stellposition und die anliegende Steuerspannung. Bei einer Regelanforderung wird die aktuelle Fahrtrichtung im LCD-Display durch einen Pfeil dargestellt. Im Fehlerfall wird der zu-gehörige Fehlercode angezeigt und durch die dauerhaft rot leuchtende LED signalisiert.

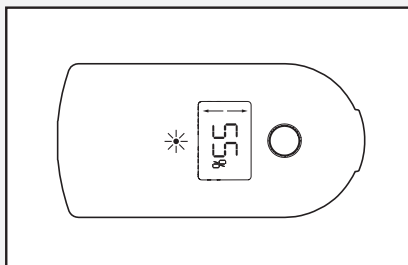

**Fehlercodes | gilt nur für Fig. 616 2G**

Fehler werden durch einen Fehlercode angezeigt. Die nachstehende Tabelle erläutert die verschiedenen Fehlercodes und Fehlerkorrekturen.

Fehlercode	Beschreibung	Fehlerkorrektur
E7	Blockade während Initialisierungsfahrt an nicht erlaubter Stelle	<ol style="list-style-type: none"> <li>1. Stellantrieb von der Spannung trennen</li> <li>2. Stellwelle mit dem manuellen Handversteller aus der Endlage bewegen</li> <li>3. Erneute Initialisierung nach Wiedereinschalten der Spannung. Bei wiederholtem Auftreten des Fehlers ist der Kundendienst hinzuzuziehen.</li> </ol>
E8	Motorstrom zu gering	<ol style="list-style-type: none"> <li>1. Neuinitialisierung durch Aus- und Einschalten des Stellantriebs.</li> <li>2. Konnte der Fehler nach maximal drei Versuchen nicht selbsttätig behoben werden, ist der Kundendienst hinzuzuziehen.</li> </ol>
E9	Zu langes Fahren in eine Richtung	<ol style="list-style-type: none"> <li>1. Neuinitialisierung durch Aus- und Einschalten des Stellantriebs.</li> <li>2. Konnte der Fehler nach maximal drei Versuchen nicht selbsttätig behoben werden, ist der Kundendienst hinzuzuziehen.</li> </ol>

1

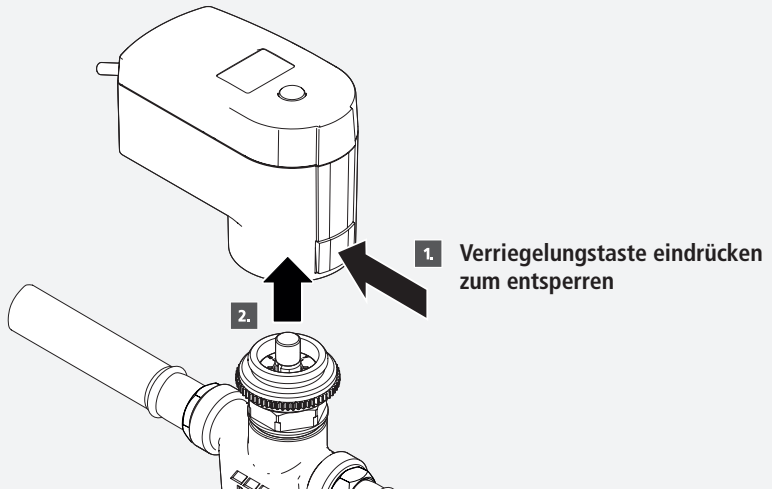

2

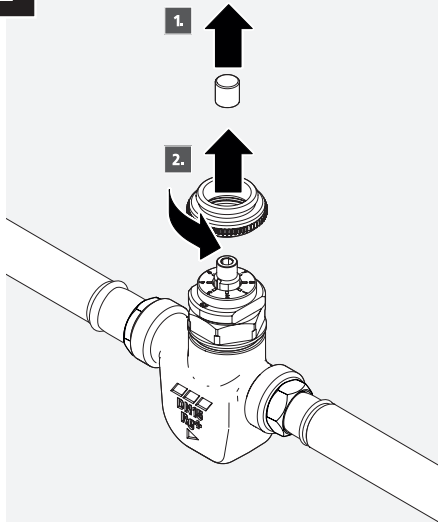

**Hinweis!**  
Prüfen Sie, ob die Verlängerungskappe noch montiert ist und entfernen Sie diese.

3

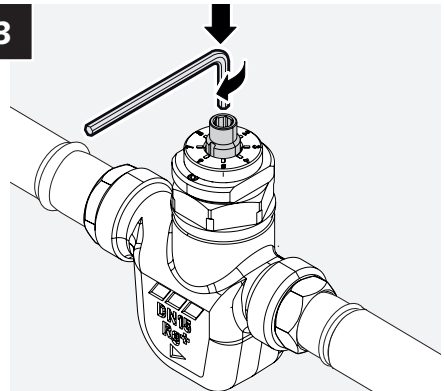

**Hinweis!**  
Nur im montierten Zustand per Hand absperren!



**Hinweis!**  
Spindel muss beim anschließenden Öffnen komplett nach links in den Anschlag gedreht sein, damit die Regulierfunktion wieder gegeben ist!

# 8

## Instandhaltung

1

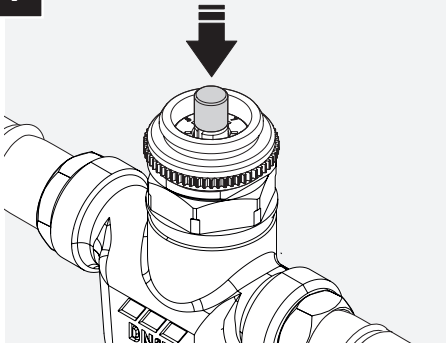

2

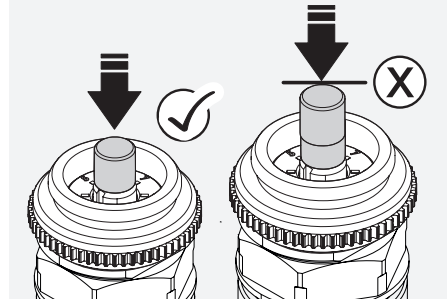

3

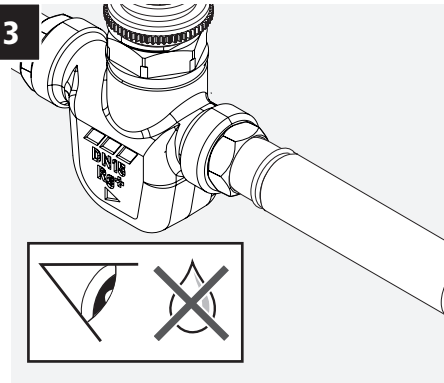

4

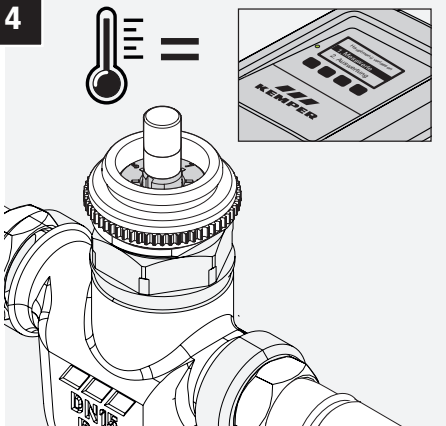

### Wartungsintervall

1x jährlich

### 1–2: Ventil eindrücken

Durch das Eindrücken im Betrieb werden Ablagerungen gelöst und das Ventil gereinigt.

### 3: Sichtkontrolle

Auf Leckagen prüfen.

Bei Leckagen Ventil austauschen.

### 4: Temperatur prüfen

Temperatur am Regler prüfen.

Temperaturen über die Entnahmemarmatur prüfen.

### Funktionsprüfung

Regulierfunktion, ggf. Spülfunktion und Absperrfunktion prüfen.

### Funktionsprüfung/

### Neuinitialisierung Stellantrieb

Prüfung im montierten Zustand.

**Demontage**

1. Ventil ggf. spannungsfrei schalten.
2. Leitungen absperren.
3. Ggf. Stellantrieb demontieren.
4. Verschraubungen lösen und Ventil von Leitungen trennen.

**Entsorgung**

Beachten Sie die örtlichen Vorschriften zur Abfallverwertung und -beseitigung. Entsorgen Sie das Produkt nicht mit dem normalen Hausmüll, sondern sachgemäß.

Bestellnr.	Ersatzteil/Zubehörteil
4712701500	Dämmschale (Zubehörteil)
6150000100	Stellantrieb 230 V (Ersatzteil)
6150200100	Stellantrieb 230 V (neues Ersatzteil)
6160000100	Stellantrieb 24 V (Ersatzteil)
6160200100	Stellantrieb 24 V (neues Ersatzteil)
6170G01500	KHS CoolFlow Kaltwasser-Reguliventil ohne Stellantrieb (Ersatzteil)

**Passender Ventiladapter**

Kemper Herstellervorgabe für die Fig. 615 2G I 616 2G.

Ventiladapter VA 80 – M30 x 1,5 8,5 mm

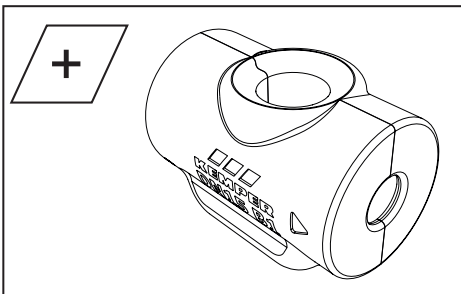
**Dämmschale**

Als Zubehör steht eine Dämmschale zur Verhinderung von Energieverlust, Tauwasserbildung und Verkeimung zur Verfügung.

DE	<b>Montage- und Bedienungsanleitung</b> KHS CoolFlow Kaltwasser-Regulierventil Fig. 615 0G   616 0G   617 0G	» 2
EN	<b>Operating instructions</b> KHS CoolFlow Cold water regulating valve Fig. 615 0G   616 0G   617 0G	» 21
FR	<b>Manuel d'utilisation</b> KHS CoolFlow Robinet de régulation d'eau froide Fig. 615 0G   616 0G   617 0G	» 41
IT	<b>Istruzioni per l'uso</b> KHS CoolFlow Valvola di regolazione dell'acqua fredda Fig. 615 0G   616 0G   617 0G	» 61
NL	<b>Bedieningshandleiding</b> KHS CoolFlow Koudwater-inregelafsluiter Fig. 615 0G   616 0G   617 0G	» 81

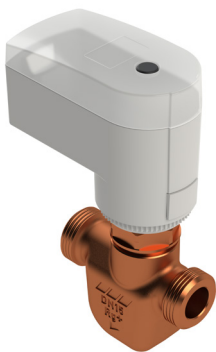

Fig. 615 2G

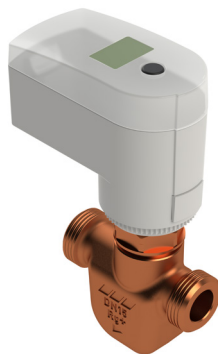

Fig. 616 2G



Fig. 615 0G | 616 0G | 617 0G

**Note!**

Scan the QR code to obtain the relevant instructions for these product variants.

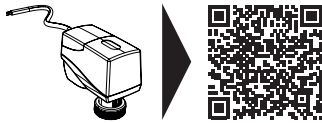

[https://www.kemper-group.com/media/crossbase/dok\\_anl\\_k410061500001-00\\_sall\\_ain\\_v106.pdf](https://www.kemper-group.com/media/crossbase/dok_anl_k410061500001-00_sall_ain_v106.pdf)

**Approvals**

ÜA



WRAS

**Table of contents**

Safety instructions	23
1 Technical data	24
2 Structure and function	26
3 Setting	27
4 Assembly	29
5 Electrical connection	31
6 Function displays	36
7 Shut off by hand	38
8 Maintenance	39
9 Dismantling and disposal	40
10 Spare parts and accessories	40

**Manufacturer's address**

Gebr. Kemper GmbH + Co. KG  
Harkortstraße 5  
57462 Olpe, Germany  
Tel.: +49 2761 891-0  
Web: [www.kemper-group.com](http://www.kemper-group.com)

**After-sales service**

Service hotline  
Tel.: +49 2761 891 800  
Mail: [anwendungstechnik@kemper-group.com](mailto:anwendungstechnik@kemper-group.com)

**About this manual**

Read this manual carefully before starting installation or operation and follow the instructions! Keep the manual in a safe place for future reference!

Illustrations in this manual serve for a basic understanding and may differ from the actual system configuration.

**Liability**

- The manufacturer assumes no warranty or liability in the event of:
- Failure to observe the instructions in this manual.
- Incorrect installation and/or operation.
- Unauthorised modification of the product.
- Other faulty operation.

**Intended use**

The KHS CoolFlow cold water regulating valve (hereinafter "Valve") regulates, flushes and shuts off drinking water circulation circuits in installations with KHS hygiene system. Any other use is considered contrary to the intended use.

**Misuse**

Do not use the valve for the circulation of substances other than drinking water and only within the operating limits indicated in the technical data.



## Safety instructions

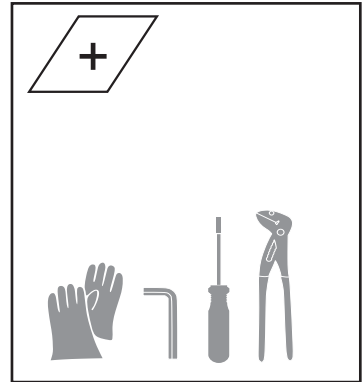
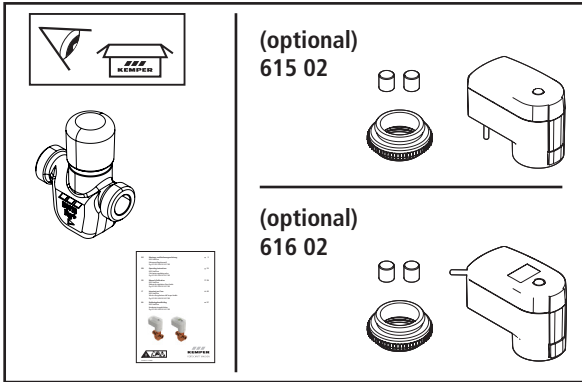

### Safety instructions

Please observe and follow the safety instructions in the manual. Failure to observe the instructions may result in injury or even death and in damage to property.

Labelling of important warning information:



#### Danger!

Indicates hazards that may result in severe or fatal injury.



#### Warning!

Indicates hazards that may result in injury, damage to property or contamination of the drinking water.



#### Note!

Indicates hazards that may result in damage to the system or malfunctions.

### Sources of danger



#### Danger!

Danger of fatal electric shock!  
Disconnect the system from the power supply before carrying out work.



#### Warning!

Risk of injury due to improper installation!  
Installation and maintenance may only be carried out by a plumbing specialist.



#### Warning!



Health hazard from residues in lines!  
Always flush the supply lines in accordance with DIN EN 806-5 and VDI/DVGW 6023 after carrying out installation and maintenance work (see section 7, illustration 1-2).



#### Note!

Risk of equipment damage from excessive temperatures during thermal disinfection!  
Remove the regulating valve with carrying out thermal disinfection and insert a fitting.

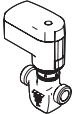
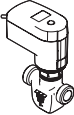
During installation, observe:  
DIN EN 806 | DIN EN 1717 | DIN 1988

	Figure No.:	Product variant	Function
	615 2G	With 230 V servo drive	For master/slave system
	616 2G	With 24 V servo drive	For BMS with position feedback
	617 0G	Without servo drive	No flushing

Parameter	Value	Unit
Adjustment range	15 to 22	°C
Pressure stage	10	PN
Max. operating temperature medium	50	°C
Cv min - see section 3	0,03	m³/h
Cv max - see section 3	1,72	m³/h
Cv flush (only with servo drive) - see section 3	2,2	m³/h
Connection size	15	DN
Dimensions (H x L x W, with servo drive)	156,5 x 90 x 45	mm
Dimensions (H x L x W, without servo drive)	91,5 x 73 x 31	mm

## 1

## Technical data

Servo drive	Fig. 615 2G (230 V)		Fig. 616 2G (24 V)	
	Power supply	230 V AC (50 Hz)		24 V AC (50/60 Hz)
Power consumption dimensioning	5,8 VA		4,4 VA	1,9 W
Power consumption nominal	3,5 VA		2,0 VA	1,0 W
Max. inrush current	Briefly max. 10 A			
Connection cable length	1,0 m			
Cable cross-section	3 x 0,75 mm <sup>2</sup>		4 x 0,22 mm <sup>2</sup>	
Max. ambient temperature	50 °C			
Max. ambient humidity	0 - 85 % (non-condensing)			
Overvoltage category	II		III	
Actuating force	200 N			
Contamination level	2			
Protection class in acc. with EN 60730	2		3	
Max. valve stroke	8,5 mm (Error message and actuators can be read via LED colours)		8,5 mm (Position and applied control voltage control voltage can be read)	
Actuator time	15 s/mm			
Display	LED multicoloured		LED multicoloured & LCD	

**Note!**

The minimum cycle time in 3-point mode is  $\geq 2$  seconds. If the drive has a shorter switch-on time, a correct switch-off cannot be guaranteed.

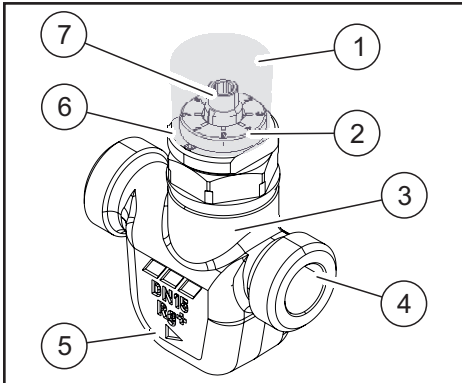

1	Protective cap
2	Position indicator
3	Valve housing
4	Pipe connections
5	Flow direction indicator
6	Motor mounting / Temperature adjustment
7	Spindle
8	Balancing cone

### Function

The position of the valve determines the function.

1. **Regulating function:** The thermal regulation function ensures automatic hydraulic balancing of the cold water circulation system.
2. **Flushing function:** The flushing function enables a turbulent flow through all areas of the drinking water installation.
3. **Shut-off function:** The electric shut-off function is used to shut-off all cold water regulating valves that have been installed. During the flushing process, all cold water regulating valves except for the flushing-relevant ones are shut off. The flushing function (2.) can now be carried out on the flushing-relevant cold water regulating valve. The system can be shut off from a central point as described in order to carry out the flushing process one after the other.

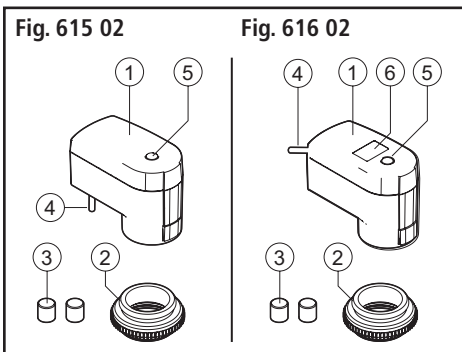
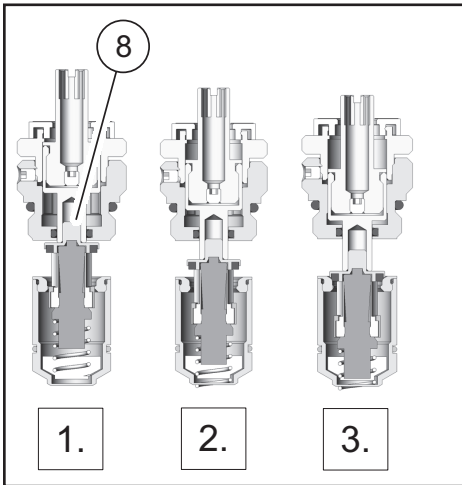

### Servo drive

The servo drive enables the flushing function.

1	Servo drive housing
2	Valve adapter VA 80 - M30 x 1.5 8.5 mm
3	Extension cap (1x as a replacement in the scope of delivery)
4	Connection cable
5	LED display
6	LC display with status indicator

## 2

## Structure and function

### Operating environment

The regulating valve is intended for use in drinking water installations with the KHS CoolFlow hygiene system. It can be both installed in new KHS

systems and retrofitted in existing KHS systems. Integration into existing hygiene systems is possible by controlling via master/slave or BMS.

## 3

## Setting

1

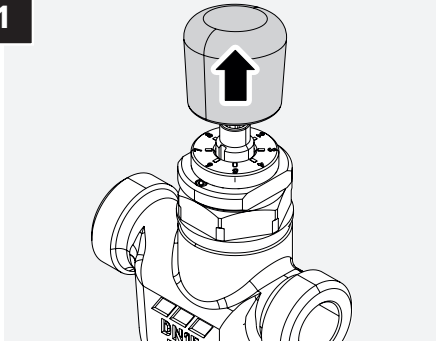

2

Release

Note!

Factory setting 3!

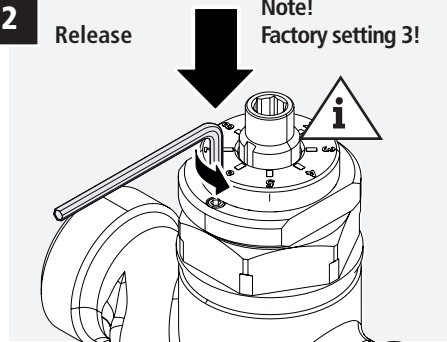

3

page 28  
Control ranges



position indicator

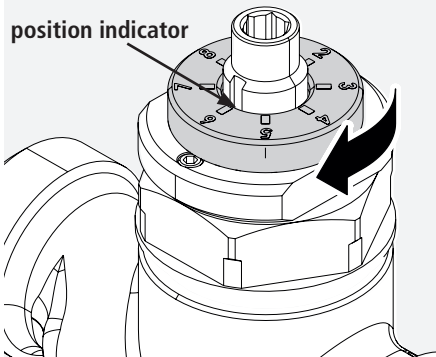

4

Fixing



Note!

Turn spindle  
anticlockwise into  
the stop!

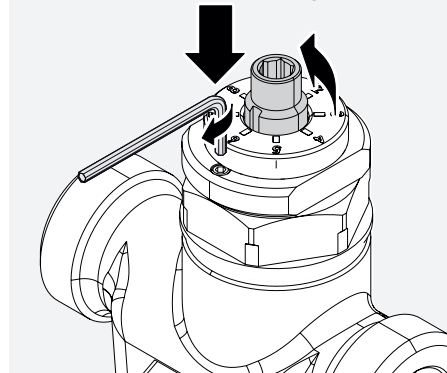

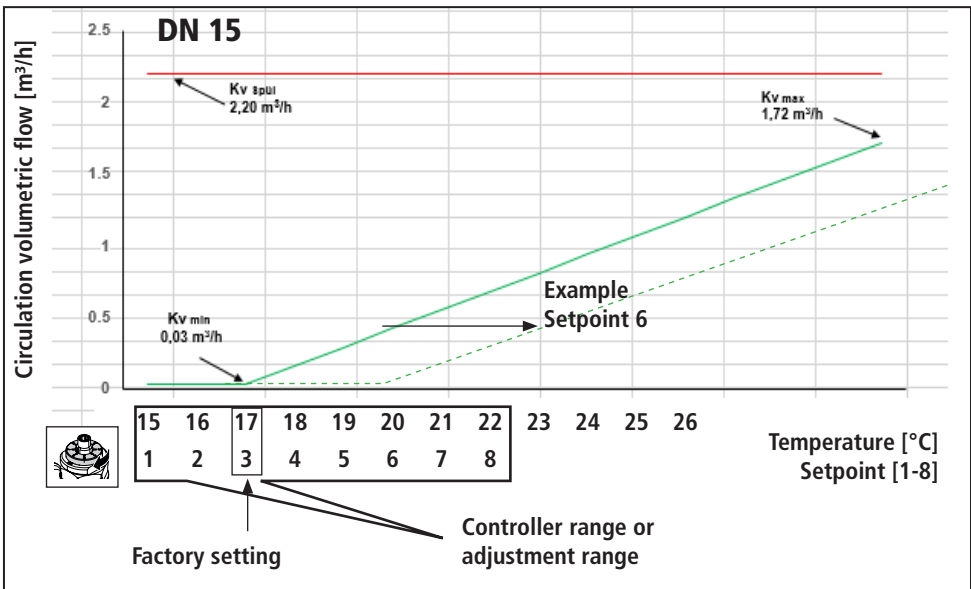
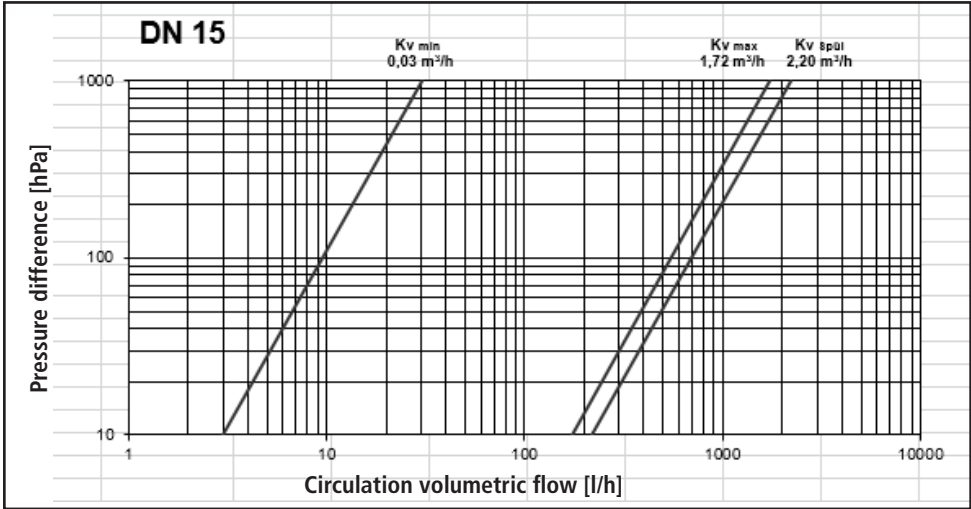

# 4

## Assembly

1



Note!  
Observe interference  
dimensions!

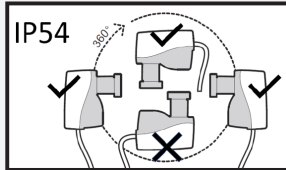

96 mm

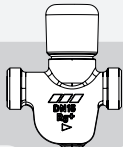

113 mm



70 mm

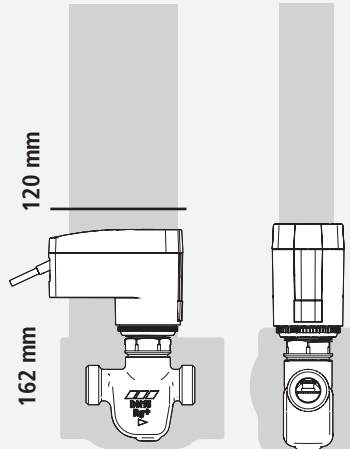

120 mm

162 mm

113 mm

70 mm

2

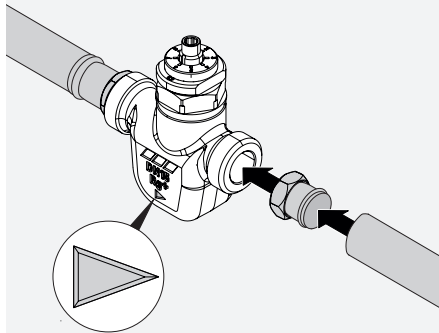

Note!  
Observe the flow direction!  
Install in a straight pipe  
section!

3



Note!  
The following steps apply to  
versions 615 2G and 616 2G.

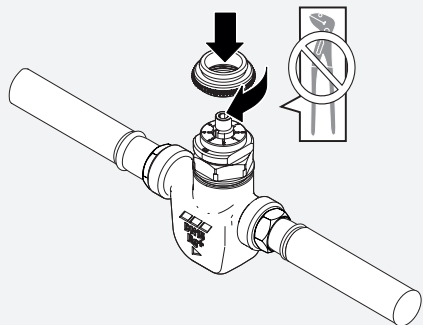

4

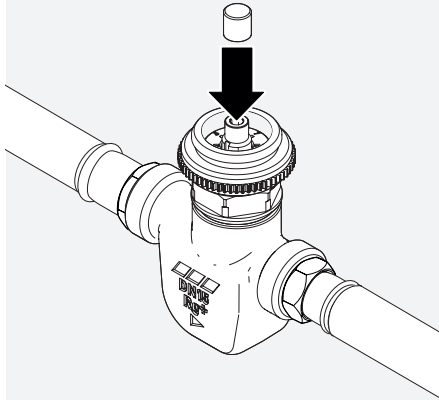

**Note!**  
An extension cap is included  
in the scope of delivery as a  
replacement.

5

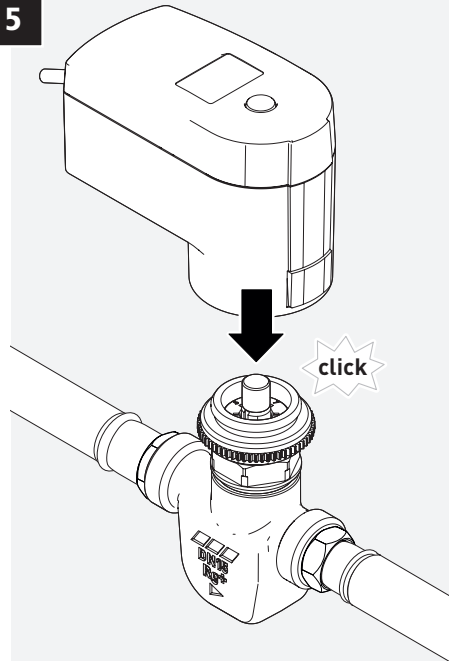

6

Fig. 615 2G (24 V version)

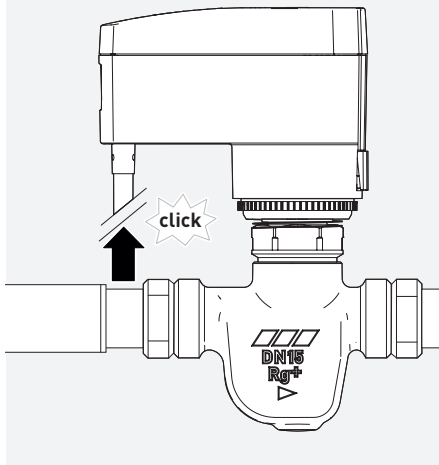

7

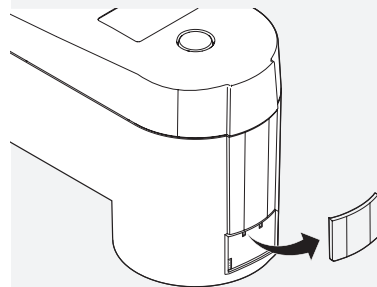

**Note!**  
Removing the locking  
button protects  
against dismantling by  
unauthorised persons.

# 5

## Electrical connection 230 V

1



**Danger!**  
Electricity! Keep the surrounding area dry!  
Disconnect the power supply before opening the housing!



**Note!**  
Fig. 615 2G and Fig. 615 02 can only be trained with the MASTER 2.1 device software higher than V2.23.15. In addition, the corresponding valve type "KHS CoolFlow V2.0" must be configured!



**Connection 230V:**  
Fig. 686 02 008

[1] → br (BN)  
[2] → sw (SW)  
[3] → gr (GR)

**Note!**  
Connection 230 V only in conjunction with KHS mini control system MASTER 2.1 or KHS mini control system SLAVE.



**Note!**  
Adequate interference suppression of the feed pipe to the drive must be ensured on site.

The 230V 3 section actuator is controlled via the KHS Mini Control System MASTER 2.1. The following pipes are recommended for the installation of a 230 V system:

- Sheathed pipe: NYM 5x1.5mm<sup>2</sup>
- Riser: NYIF 5x1.5mm<sup>2</sup>

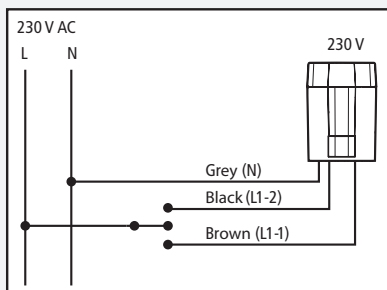

Function	Description
Grey (N)	Neutral conductor
Voltage on black (L1-2)	Valve pressure plate retracts
Voltage to brown (L1-2)	Valve pressure plate extends
No voltage on brown and black	Valve pressure plate remains in the current position

## 1

**Initialisation:**

After switching on the power supply, the KHS CoolFlow cold water balancing valve Fig. 616 2G performs a proportional initialisation. In the initialisation phase, the actuator determines the travel distance and shows „In“ (for initialisation) on the display. At the same time the green LED flashes.

First, the valve pressure plate is fully retracted, which determines the inner end stop of the actuator. The valve pressure plate then extends and, along the way, first determines the position of contact with the valve tappet and the second end stop, when the end of the valve path is reached and the actuator has come to a standstill.

The end of initialisation is indicated by the green LED going out, „In“ in the display going out and the alternating display of the control voltage applied and the current setting position appearing.

**Note!**

For an initialisation phase, the KHS CoolFlow cold water balancing valve Fig. 616 2G needs proportional max. 7 min. During initialisation, the actuator does not react to the control voltage applied.

**Operation**

The 24 V actuator is controlled via a 0 - 10 VDC control signal from the building management system. The control signal enables precise control and positioning of the actuator. Alternatively, a PWM signal can also be applied to the control voltage input see diagram:

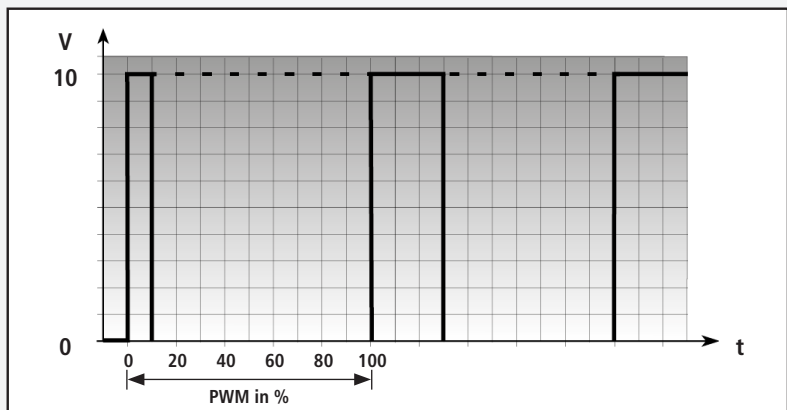

### Pulse width frequency 100 Hz to 1000 Hz

After initialisation, the control voltage applied is converted proportionally into a control position. The actuator uses the control voltage, the set travel distance or the measured travel distance travel (depending on the mode) and moves precisely to this position.



#### Note!

- 0 V The complete valve tappet is extended
- 4.6 V Valve tappet in flush position
- 10 V The complete valve tappet is retracted

#### Control CoolFlow 24 V servo drive

Function	Voltage	Description
1 Regulating function	10 V	Regulating the valve
2 Flushing function	4,6 V	Valve flushes (+/- 0,5 V Kv flush)
3 Stop function	0 V	Valve closed

## 2

**Feedback signal**

The feedback signal of the 24 V actuator enables direct feedback of the current operating status to the DDC system via a 0 to 10 V signal. Voltages from 1 to 9 volts provide information about the actuator position, voltages  $< 0.5$  V and  $> 9.5$  V signalise errors that have occurred. The connection of the feedback signal is voltage-proof up to 24 V.

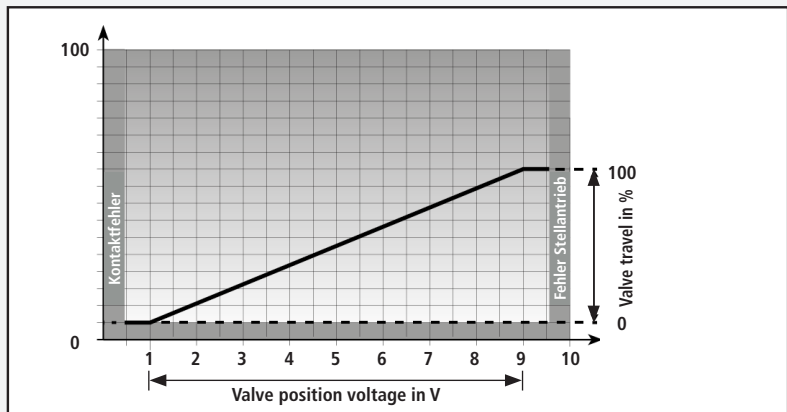

## Electrical connection 24 V actuator AC/DC L1 (+) L2 (-)

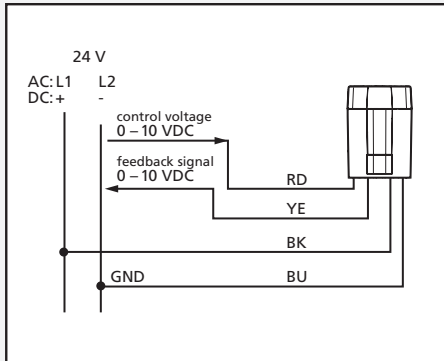
**Connection pipe**

The following maximum pipe lengths are recommended for the installation of a 24 V system:

Pipes	Cross-section	Length
Standard DCC pipes	0,22 mm <sup>2</sup>	20 m
J-Y(ST)Y	0,8 mm <sup>2</sup>	45 m
NYM / NYIF	1,5 mm <sup>2</sup>	136 m

**Transformer/power pack**

A safety transformer in accordance with EN 61558-2-6 or a switching power supply in accordance with EN 61558-2-16 must be used.

### Function indicators via LED

The Motoric Valve Drive has LEDs for signalling operating states: 230 V 3-point via a multicoloured LED. Green, orange and red are used as signal colours. Signalling only takes place when the actuator is supplied with operating voltage. The LED lights up approx. 3 seconds after switching on in order to prevent it flashing when pulsed.

If the actuator runs against the upper or lower stop, the motor switches off after a time overrun, as does the LED.

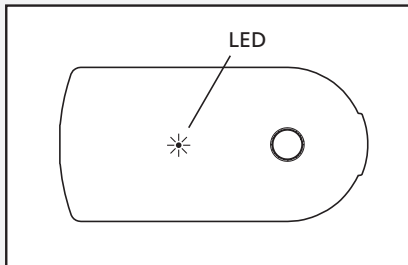

LED signal	Meaning
Red	In the event of an error
Green	Valve pressure plate retracts
Orange	Valve pressure plate extends

### LCD display | only applies to Fig. 616 2G

The LCD display of the 24 V actuator alternately shows the control position and the control voltage applied. When a control request is made, the current direction of travel is shown by an arrow on the LCD display. In the event of an error, the corresponding error code is displayed and signalled by the permanently illuminated red LED.

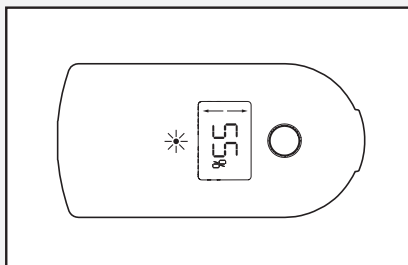

**Error codes | only applies to Fig. 616 2G**

Errors are indicated by an error code. The table below explains the various error codes and error corrections.

Error code	Description	Error correction
E7	Blockage during initialisation drive at unauthorised position	<ol style="list-style-type: none"> <li>1. Disconnect the actuator from the power supply</li> <li>2. Move the adjusting shaft with the manual adjuster from the end position</li> <li>3. Re-initialisation after switching the voltage. If the error occurs repeatedly, contact customer services.</li> </ol>
E8	Motor current too low	<ol style="list-style-type: none"> <li>1. Re-initialisation by switching the actuator off and on.</li> <li>2. If the error could not be rectified automatically after a maximum of three attempts, customer services must be called in.</li> </ol>
E9	Driving too long in one direction	<ol style="list-style-type: none"> <li>1. Re-initialisation by switching the actuator off and on.</li> <li>2. If the error could not be rectified automatically after a maximum of three attempts, customer services must be called in.</li> </ol>

1

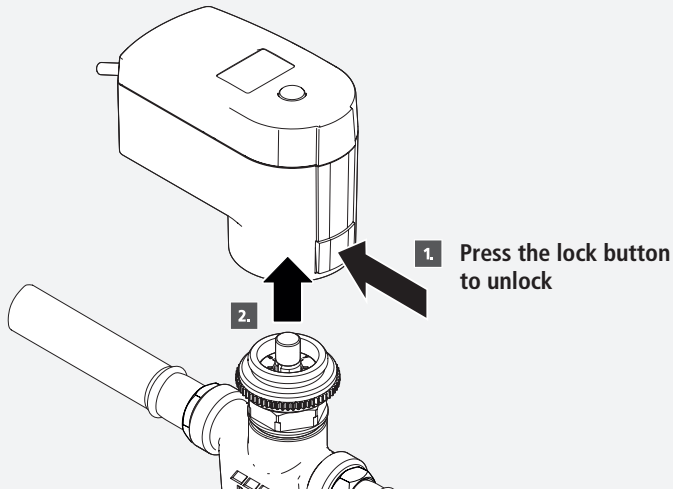

2

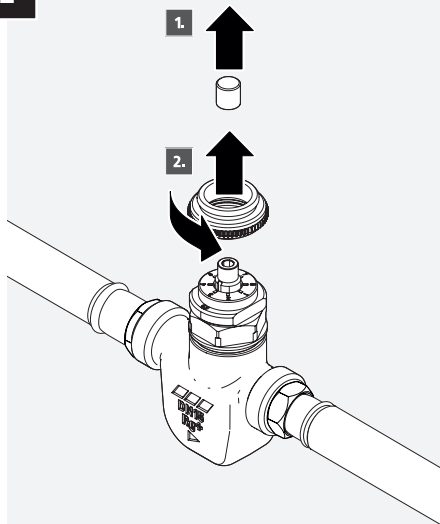

**Note!**  
Check whether the extension cap is still fitted and remove it.

3

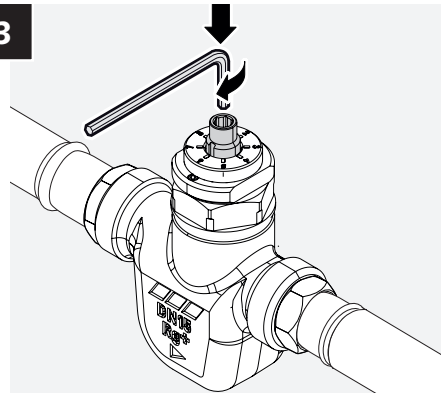

**Note!**  
Shut off by hand only when assembled!



**Note!**  
The spindle must be fully turned anticlockwise into the stop during subsequent opening to ensure that the regulating function is restored!

# 8

## Maintenance

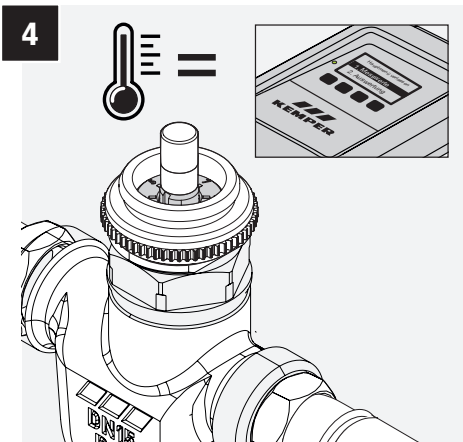
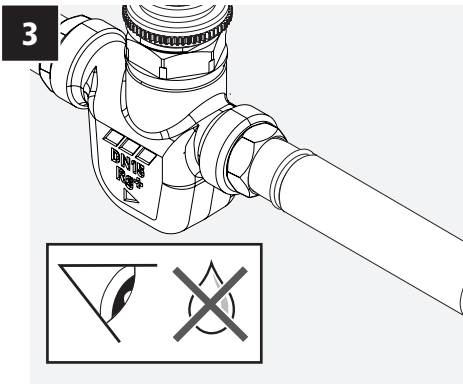
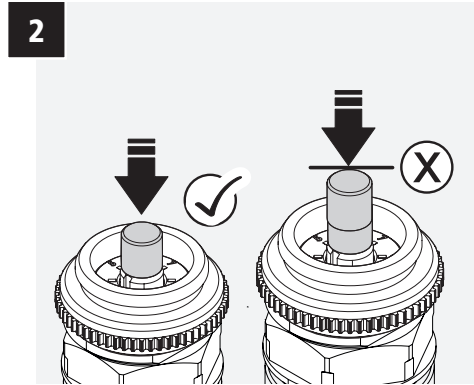
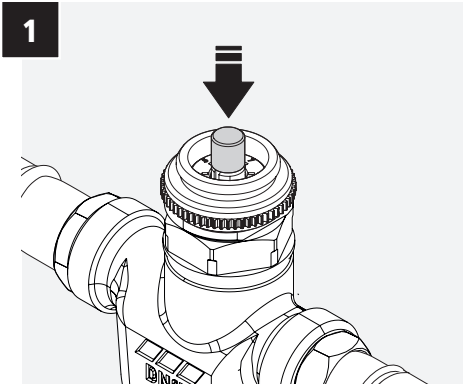

### Maintenance interval

1x per year

### 1-2: Press in the valve

Pressing in the valve during operation removes deposits and cleans the valve.

### 3: Visual inspection

Inspect for leaks.

Replace valve if leaks are discovered.

### 4: Check temperature

Temperatur am Regler prüfen.

Check temperatures via the tap.

### Function test

Test the regulator function, with flushing and shut-off function, if necessary.

### Functional check/ reinitialisation of servo drive

Check when installed.

## Dismantling and disposal

### Dismantling

1. Disconnect the valve from the mains power supply, if necessary.
2. Shut off the lines.
3. Remove the servo drive, if necessary.
4. Loosen the screw fittings and remove the valve from the lines.



### Disposal

Observe the local regulations on waste disposal and waste recycling. Do not dispose of the product with the normal household waste; dispose of it correctly.

## 10

## Spare parts and accessories

Order No.	Spare part/accessory
4712701500	Insulating shell (accessory)
6150000100	230 V servo drive (spare part)
6150200100	230 V servo drive (new spare part)
6160000100	24 V servo drive (spare part)
6160200100	24 V servo drive (new spare part)
6170G01500	KHS CoolFlow Cold water regulating valve without actuator

### Suitable valve adapter

Kemper manufacturer's specification for Fig. 615 2G | 616 2G.  
Valve adapter VA 80 - M30 x 1.5 8.5 mm

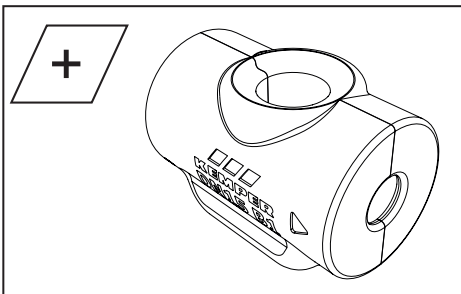

### Insulating

An insulating shell is available as an accessory to prevent energy losses, formation of condensation and microbial contamination.

DE	<b>Montage- und Bedienungsanleitung</b> KHS CoolFlow Kaltwasser-Regulierventil Fig. 615 0G   616 0G   617 0G	» 2
EN	<b>Operating instructions</b> KHS CoolFlow Cold water regulating valve Fig. 615 0G   616 0G   617 0G	» 21
FR	<b>Manuel d'utilisation</b> KHS CoolFlow Robinet de régulation d'eau froide Fig. 615 0G   616 0G   617 0G	» 41
IT	<b>Istruzioni per l'uso</b> KHS CoolFlow Valvola di regolazione dell'acqua fredda Fig. 615 0G   616 0G   617 0G	» 61
NL	<b>Bedieningshandleiding</b> KHS CoolFlow Koudwater-inregelafsluiter Fig. 615 0G   616 0G   617 0G	» 81

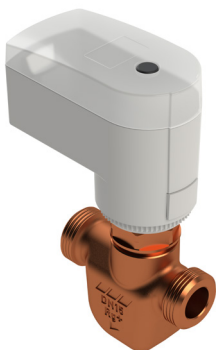

Fig. 615 2G



Fig. 616 2G



Fig. 615 0G | 616 0G | 617 0G

**Note!**

Scannez le code QR pour obtenir pour obtenir les instructions respectives sur ces variantes de produits.

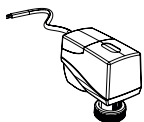

[https://www.kemper-group.com/media/crossbase/dok\\_anl\\_k410061500001-00\\_sall\\_ain\\_v106.pdf](https://www.kemper-group.com/media/crossbase/dok_anl_k410061500001-00_sall_ain_v106.pdf)

**Homologations**

ÜA



WRAS

**Sommaire**

Consignes de sécurité	43
1 Caractéristiques techniques	44
2 Structure et fonction	46
3 Réglage	47
4 Montage	49
5 Raccordement électrique	51
6 Indicateurs de fonction	56
7 Fermeture manuelle	58
8 Entretien	59
9 Démontage et mise au rebut	60
10 Pièces de rechange et accessoires	60

**Adresse du fabricant**

Gebr. Kemper GmbH + Co. KG

Harkortstraße 5

D-57462 Olpe

Tél.: +49 2761 891-0

Site Internet: [www.kemper-group.com](http://www.kemper-group.com)**Service après-vente**

Ligne d'assistance téléphonique du service après-vente

Tél.: +49 2761 891 800

E-mail: [anwendungstechnik@kemper-group.com](mailto:anwendungstechnik@kemper-group.com)**A propos de cette notice**

Lisez soigneusement cette notice avant le montage ou l'utilisation et respectez les instructions!

Conservez la notice pour une utilisation ultérieure!

Les illustrations de cette notice ont pour but de donner au lecteur une compréhension de base et peuvent diverger du modèle existant.

**Responsabilité**

Le fabricant n'assume aucune responsabilité ni aucune garantie:

en cas de non-respect de cette notice, d'installation et/ou d'utilisation incorrecte(s), de modification autonome du produit et de toute autre utilisation inappropriée.

**Utilisation conforme à l'utilisation prévue**

Le robinet de régulation d'eau froide KHS Cool-Flow (ci-après «robinet») régule, rince et bloque les circuits de circulation de l'eau potable dans les installations équipées d'un système d'hygiène KHS. Toute autre utilisation est considérée comme non conforme à la destination prévue.

**Utilisation inappropriée**

N'utilisez pas le robinet pour la circulation d'autres matières autres que l'eau potable et employez-le que dans les limites d'utilisation indiquées dans les caractéristiques techniques.



## Consignes de sécurité

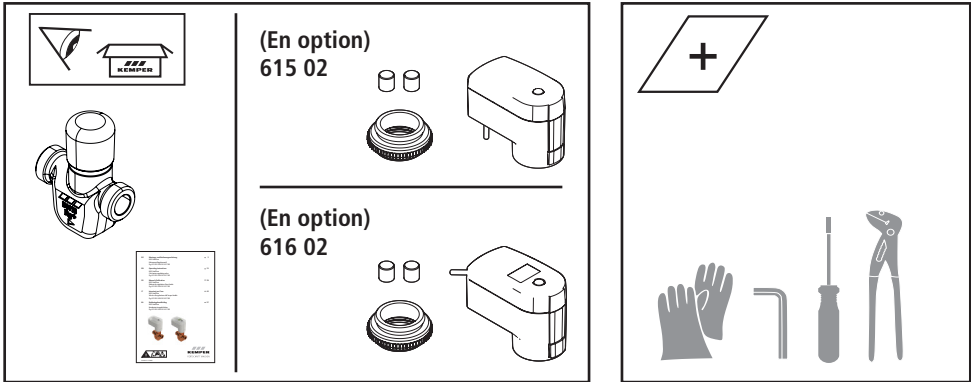

### Consignes de sécurité

Respectez impérativement les avertissements de cette notice ! Le non-respect des consignes de sécurité peut entraîner la mort, des blessures ou des dommages matériels.

Marquage des avertissements importants:



#### Danger!

Indique les dangers pouvant entraîner la mort ou des blessures graves.



#### Avertissement!

Indique les dangers pouvant entraîner des blessures, des dégâts matériels ou une contamination de l'eau potable.



#### Remarque!

Indique les dangers pouvant entraîner des détériorations sur l'installation ou des dysfonctionnements.

### Sources de danger



#### Danger!

Danger de mort dû au courant électrique!

- Mettez systématiquement le système hors tension avant tous travaux à effectuer dessus.



#### Avertissement!

Risque de blessures en cas de montage incorrect!

- Uniquement un spécialiste en sanitaire est autorisé à effectuer le montage et l'entretien.



#### Avertissement!

Risque pour la santé dû aux résidus se trouvant dans les conduites!

- Rincez systématiquement les conduites après le montage et la maintenance conformément aux normes DIN EN 806-5 et VDI / DVGW 6023 (voir le chapitre 7 figures 1 et 2).





#### Remarque!

Dommages matériels dus à des températures trop élevées lors de la désinfection thermique!

- Rincez systématiquement le robinet de régulation pour effectuer une désinfection thermique et insérez un raccord.

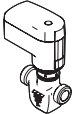
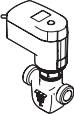
A prendre en compte lors du montage:  
DIN EN 806 | DIN EN 1717 | DIN 1988

	Figure n°	Variante du produit	Fonction
	615 2G	Avec servomoteur 230 V	Pour le système maître/esclave
	616 2G	Avec servomoteur 24 V	Pour la technique de commande du bâtiment (GLT) avec confirmation de la position
	617 0G	Sans servomoteur	Pas de fonction de rinçage

Variables	Valeur	Unité
Plage de réglage	de 15 à 22	°C
Niveau de pression	10	PN
Température de service max. du fluide	50	°C
Kv-min - voir le chapitre 3	0,03	m <sup>3</sup> /h
Kv-max - voir le chapitre 3	1,72	m <sup>3</sup> /h
Kv rinçage (seulement avec un servomoteur) - voir le chapitre 3	2,2	m <sup>3</sup> /h
Largeur nominale des raccords	15	DN
Dimensions (H x L x l, avec servomoteur)	156,5 x 90 x 45	mm
Dimensions (H x L x l, sans servomoteur)	91,5 x 73 x 31	mm

## 1

## Caractéristiques techniques

Servomoteur	Fig. 615 2G (230 V)	Fig. 616 2G (24 V)	
Alimentation électrique	230 V AC (50 Hz)	24 V AC (50/60 Hz)	24 V DC
Puissance absorbée dimensionnée	5,8 VA	4,4 VA	1,9 W
Puissance absorbée nominale	3,5 VA	2,0 VA	1,0 W
Courant de démarrage maximal	10 A maximum sur courte durée		
Longueur du câble de raccordement	1,0 m		
Section du câble	3 x 0,75 mm <sup>2</sup>	4 x 0,22 mm <sup>2</sup>	
Température ambiante maximale	50 °C		
Humidité ambiante maximale	0 - 85 % (sans condensation)		
Catégorie de surtension	II	III	
Puissance de réglage	200 N		
Degré d'encrassement	2		
Classe de protection selon EN 60730	2	3	
Course maximale de la soupape	8,5 mm (message d'erreur et courses de réglage lisibles via les couleurs des LED)	8,5 mm (position et tension de com- mande appliquée lisibles)	
Durée de réglage	15 s/mm		
Affichage	LED multicolore	LED multicolore et LCD	

**Remarque!**

La durée de cycle minimale en mode à 3 points est de 2 secondes. En cas d'un cycle plus court du servomoteur, une mise hors circuit correcte n'est plus garantie.

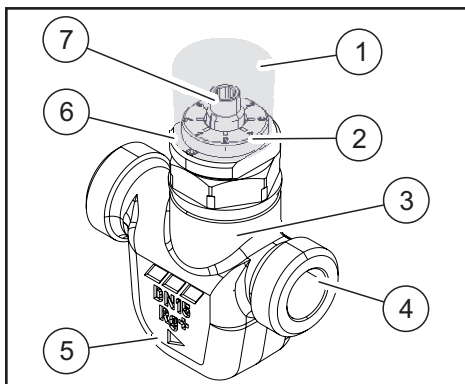

1	Capot de protection
2	Affichage de la position
3	Corps du robinet
4	Raccords des tubes
5	Affichage du sens d'écoulement
6	Support moteur / réglage de la température
7	Broche/Réglage de la température
8	Cône de régulation

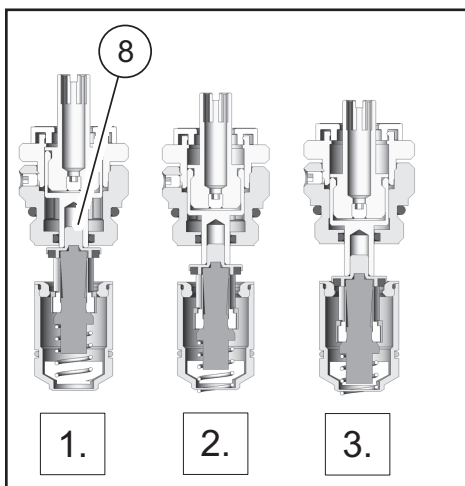

### Fonction

La position du robinet détermine la fonction.

1. Fonction de régulation: la fonction de régulation thermique garantit une compensation hydraulique automatique du système de circulation d'eau froide
2. Fonction de rinçage: la fonction de rinçage permet un écoulement turbulent dans toutes les zones de l'installation d'eau potable.
3. La fonction d'arrêt électrique est utilisée pour fermer toutes les vannes de régulation d'eau froide qui ont été installées. Pendant un processus de rinçage, toutes les vannes de régulation d'eau froide sont fermées, à l'exception de celles qui concernent le rinçage. La fonction de rinçage (2.) peut maintenant être exécutée sur la vanne de régulation d'eau froide relative au rinçage. Le système peut être arrêté à partir d'un point central comme décrit afin d'effectuer le processus de rinçage l'un après l'autre.

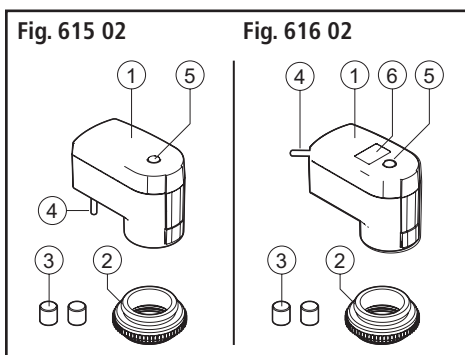

### Servomoteur

Le servomoteur permet la fonction de rinçage.

1	Corps du servomoteur
2	Adaptateur de vanne VA 80 – M30 x 1,5 8,5 mm
3	Capuchon de rallonge (1 également fourni en tant que rechange)
4	Câble de raccordement
5	Indicateur LED
6	Écran LC avec affichage d'état

## 2

## Structure et fonction

### Environnement d'utilisation

Le robinet de régulation est prévu pour une utilisation dans les installations d'eau potable équipées du système d'hygiène KHS CoolFlow. Il peut être utilisé dans des installations KHS neuves et peut équiper ultérieurement des installations KHS existantes.

Une intégration à des systèmes d'hygiène existants est possible par une commande via Maître/Esclave ou par la technique de commande du bâtiment (GLT).

## 3

## Réglage

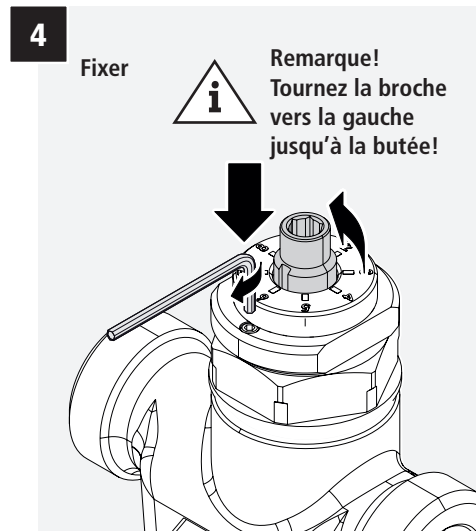
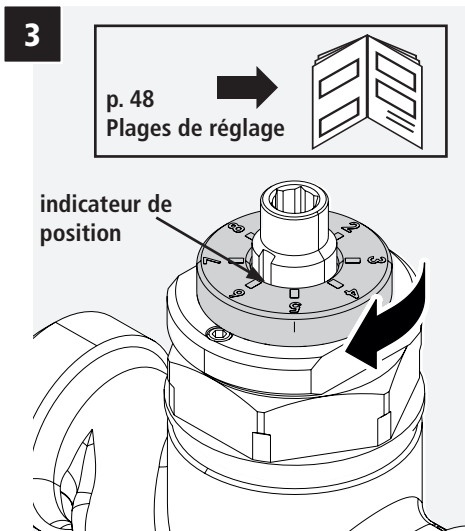
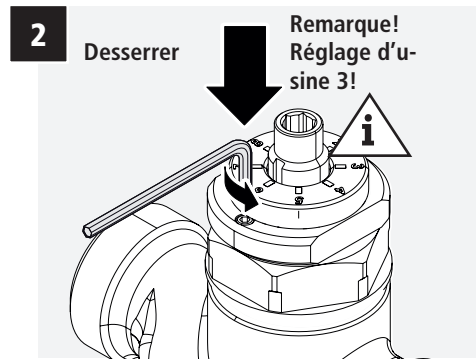
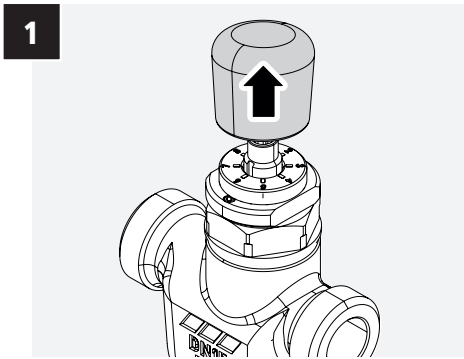

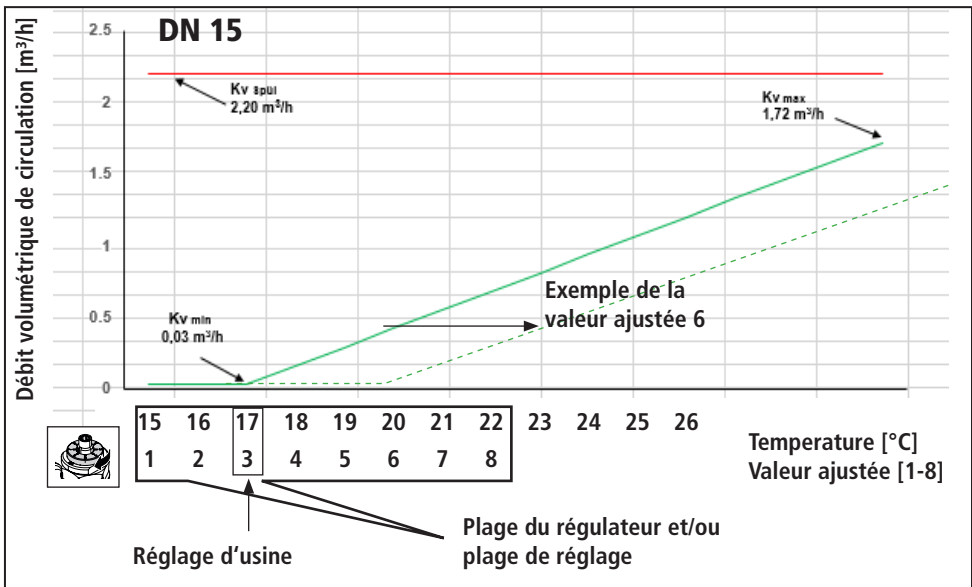
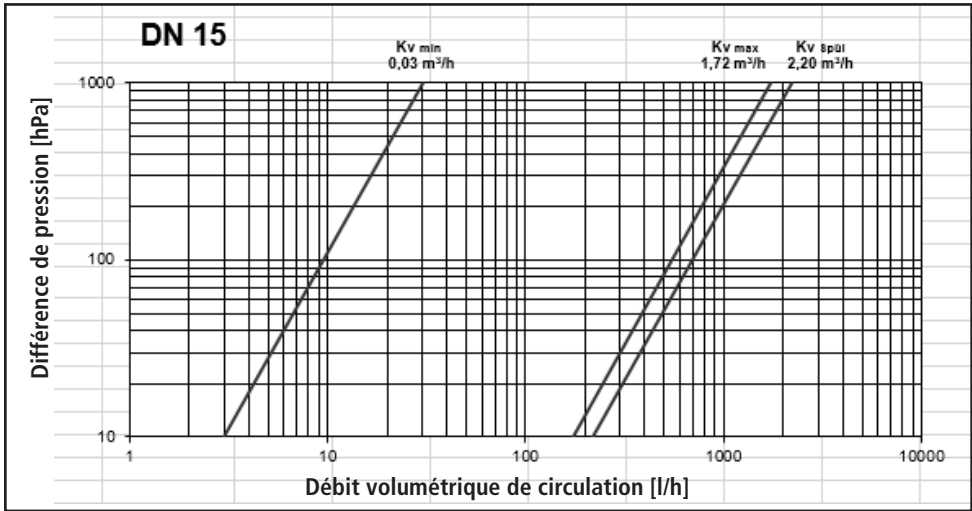

# 4

## Montage

1



Remarque!  
Respecter les dimensions  
d'écartement!

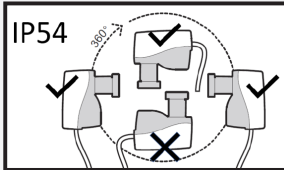

96 mm

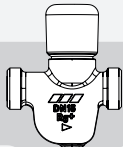

113 mm



70 mm

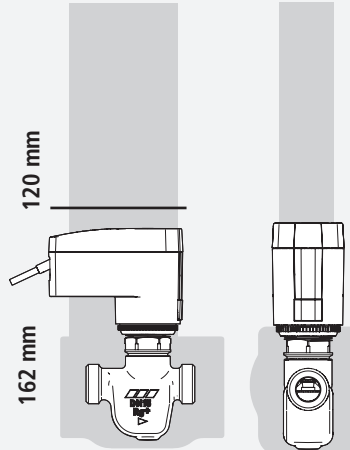

120 mm

162 mm

113 mm

70 mm

2

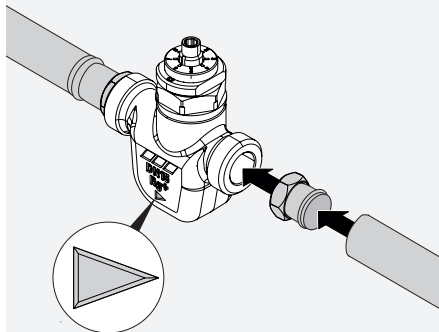

Remarque!  
Tenir compte du sens  
d'écoulement!  
A mettre en place dans une  
ligne de tubes droite!

3



Remarque!  
Les étapes de travail  
suivantes sont valables  
pour les versions 615 2G  
et 616 2G.

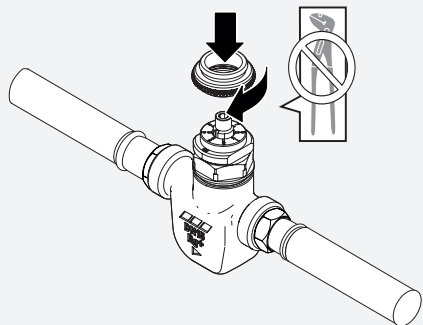

4

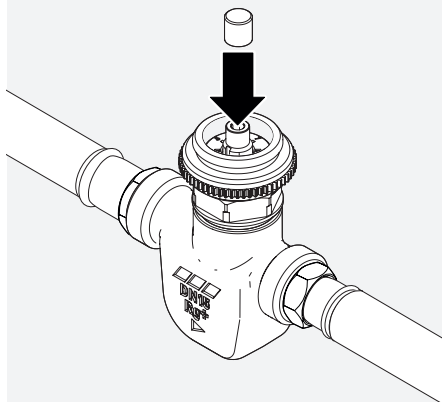

Remarque!  
Un capuchon de rallonge  
est également fourni en  
rechange.

5

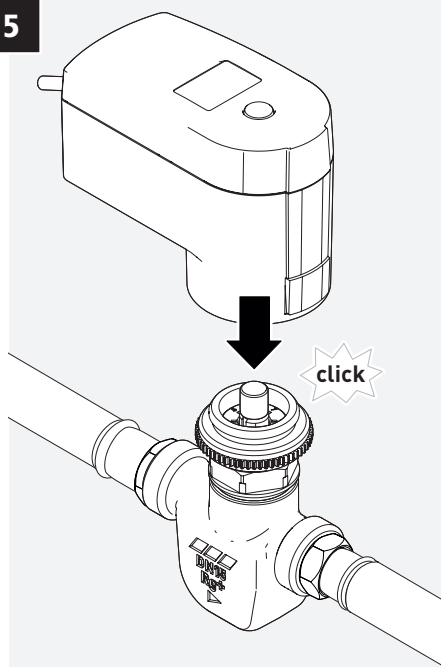

6

Fig. 615 2G (version 24 V)

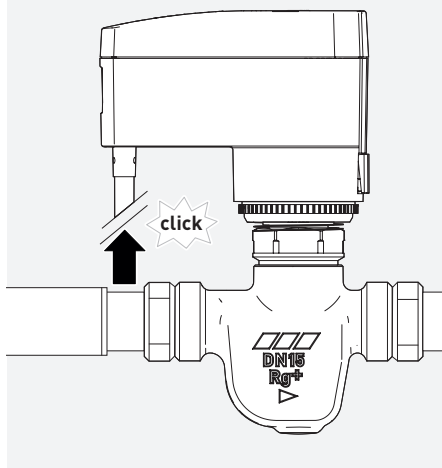

7

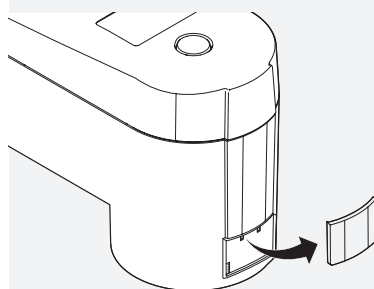

Remarque!  
Le retrait du bouton de  
verrouillage protège contre  
le démontage par des  
personnes non autorisées.

1



**Danger!**  
**Courant électr.! Garder l'environnement au sec!**  
**Mettre hors tension avant d'ouvrir le boîtier!**



**Remarque!**  
 La Fig. 615 2G et la Fig. 615 02 ne peuvent être programmées qu'avec le logiciel de l'appareil MASTER 2.1 supérieur à V2.23.15. De plus, le type de vanne correspondant «KHS CoolFlow V2.0» doit être configuré !





**Raccordement 230V:**  
 Fig. 686 02 008

[1] → br (BN)  
 [2] → sw (SW)  
 [3] → gr (GR)



**Remarque!**  
**Raccordement 230 V uniquement en association avec la mini commande du système KHS MASTER 2.1 ou KHS SLAVE.**



**Remarque!**  
 Le client doit veiller à ce que le câble d'alimentation du servomoteur soit suffisamment protégé contre les parasites.

La commande du servomoteur 3 points 230V s'effectue via la mini commande du système KHS MASTER 2.1. Pour l'installation d'un système 230 V, les lignes suivantes sont recommandées:

- Câble sous gaine: NYM 5x1,5mm<sup>2</sup>
- Câble plat: NYIF 5x1,5mm<sup>2</sup>

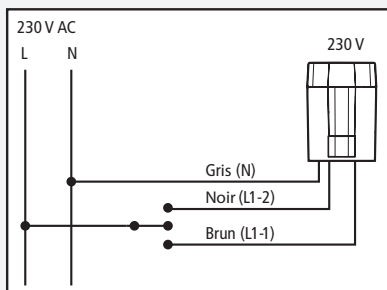

Fonction	Description
Gris (N)	Conducteur neutre
Tension sur le noir (L1-2)	Plaque de pression de la vanne rentre
Tension sur le brun (L1-2)	Plaque de pression de la vanne sort
Pas de tension sur le brun et le noir	Plaque de pression de la vanne reste à la position actuelle

## 1

**Initialisation:**

Après la mise sous tension de l'alimentation électrique, le robinet de régulation d'eau froide KHS CoolFlow Fig. 616 2G effectue proportionnellement une initialisation. Pendant la phase d'initialisation, le servomoteur détermine la course et affiche „In“ (pour initialisation) sur l'écran. En même temps, la LED verte clignote.

La plaque de pression de la vanne est d'abord complètement rentrée, ce qui permet de déterminer la butée intérieure de l'actionneur.

La plaque de pression de la vanne se déplace ensuite et détermine pendant la course tout d'abord la position du contact avec le poussoir de la vanne et la deuxième butée de fin de course lorsque la fin de la course de la vanne est atteinte et lorsque le servomoteur s'est arrêté.

La fin de l'initialisation est indiquée par l'extinction de la LED verte, la suppression de l'affichage de «In» sur l'écran et l'affichage alterné de la tension de commande appliquée et de la position de réglage actuelle.

**Remarque!**

Pour une phase d'initialisation, le robinet de régulation d'eau froide KHS CoolFlow Fig. 616 2G a besoin proportionnellement d'au maximum 7 minutes. Pendant l'initialisation, le servomoteur ne réagit pas à la tension de commande appliquée.

**Fonctionnement**

Le servomoteur de 24 V est commandé par un signal de commande de 0 - 10 VCC par l'intermédiaire de la gestion technique du bâtiment. Le signal de commande permet un pilotage et un positionnement précis du servomoteur. Il est également possible d'appliquer un signal de modulation d'impulsions (PWM) à l'entrée de la tension de commande, voir le diagramme:

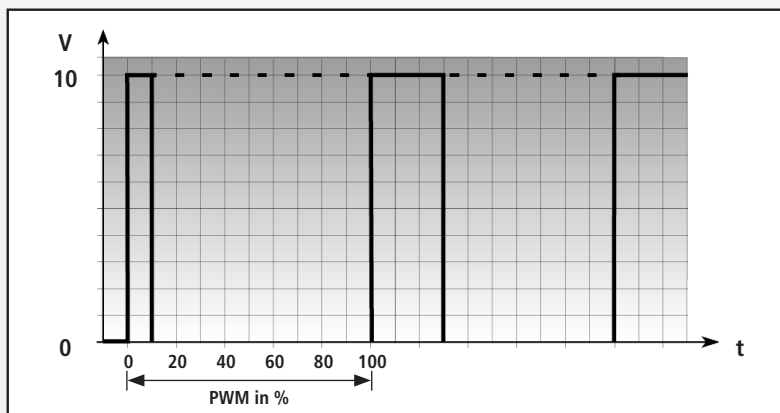

### Fréquence de modulation de largeur d'impulsions de 100 Hz à 1000 Hz

Après l'initialisation, la tension de commande appliquée est convertie proportionnellement en une position de réglage. Le servomoteur calcule la position de réglage à atteindre et s'y déplace avec précision à partir de la tension de commande, de la course de réglage réglée ou de la course mesurée (en fonction du mode).



#### Remarque!

- 0 V Le poussoir de la vanne complet est sorti
- 4,6 V Poussoir de la vanne en position de rinçage
- 10 V Le poussoir de la vanne complet est rentré

#### Commande du servomoteur CoolFlow 24 V

Fonction	Tension	Description
1 Fonction de régulation	10 V	Régulation de soupape
2 Fonction de rinçage	4,6 V	Rinçages de soupape (+/- 0,5 V Kv rinçage)
3 Fonction d'arrêt	0 V	Soupape fermée

## 2

**Signal de feedback**

Le signal de feedback du servomoteur 24 V permet, via un signal de 0 à 10 V, de fournir un feedback direct relatif à l'état de fonctionnement actuel à l'installation DDC. Les tensions de 1 à 9 V donnent des informations sur la position du servomoteur, les tensions  $< 0,5$  V et  $> 9,5$  V signalent des erreurs qui se sont produites. Le raccordement du signal de feedback est résistant à la tension jusqu'à 24 V.

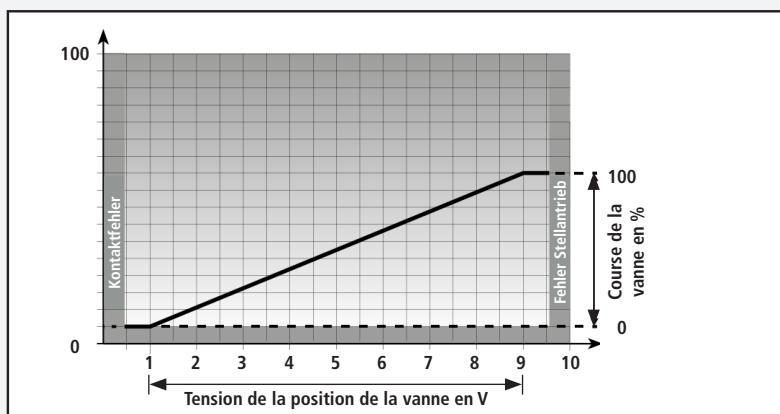

## Raccordement électrique 24V Servomoteur CA/CC L1 (+) L2 (-)

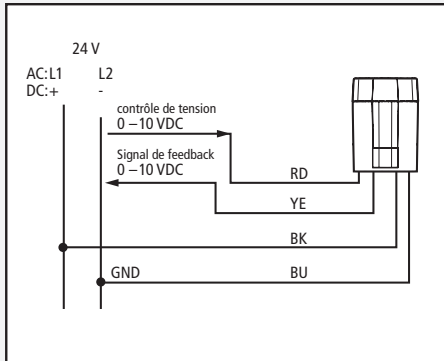

## Câble de raccordement

Les longueurs maximales de câble suivantes sont recommandées pour l'installation d'un système de 24 V:

Câble	Coupe transversale	Longueur
Câble DCC standard	0,22 mm <sup>2</sup>	20 m
J-Y(ST)Y	0,8 mm <sup>2</sup>	45 m
NYM / NYIF	1,5 mm <sup>2</sup>	136 m

## Transformateur/bloc d'alimentation

Il faut toujours utiliser un transformateur de sécurité conforme à la norme EN 61558-2-6 ou un bloc d'alimentation à découpage conforme à la norme EN 61558-2-16.

### Affichage des fonctions par LED

Pour la signalisation fonctionnelle des états de fonctionnement, le Motoric Valve Drive est doté de: servomoteur 3 points 230V via une LED multicolore. Les couleurs de signalisation utilisées sont le vert, l'orange et le rouge. Une signalisation n'a lieu que si le servomoteur est alimenté en tension de service. La LED s'allume environ 3 secondes après la mise en marche pour éviter qu'elle ne clignote en cas de commande par impulsion.

Si le servomoteur tourne contre la butée supérieure ou inférieure, le moteur s'arrête après une temporisation, tout comme la LED.

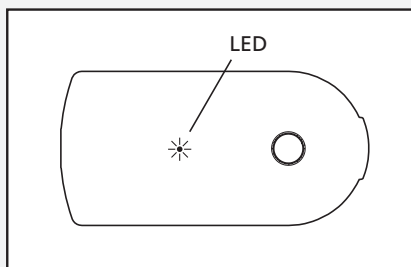

Signal LED	Signification
Rouge	Erreur
Vert	La plaque de pression de la vanne rentre
Orange	La plaque de pression de la vanne sort

### Ecran LCD | valable uniquement pour Fig. 616 2G

L'écran LCD du servomoteur 24 V affiche en alternance la position de réglage et la tension de commande appliquée. Lors d'une demande de régulation, le sens de marche actuel est représenté par une flèche sur l'écran LCD. En cas d'erreur, le code d'erreur correspondant est affiché et signalé par la LED rouge allumée en permanence.

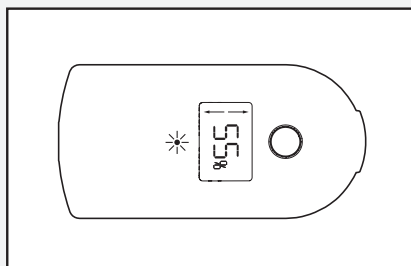

**Codes d'erreur | s'applique uniquement à la Fig. 616 2G**

Les erreurs sont indiquées par un code d'erreur. Le tableau ci-dessous explique les différents codes d'erreur et les corrections d'erreurs.

Code d'erreur	Description	Correction d'erreurs
E7	Blocage pendant la course d'initialisation à une position non autorisée	<ol style="list-style-type: none"><li>1. Déconnecter le servomoteur de la tension</li><li>2. Faire sortir l'arbre de réglage de la position finale en utilisant le dispositif de réglage manuel</li><li>3. Nouvelle initialisation après la remise sous tension de la tension. Si l'erreur se répète, contacter le service après-vente.</li></ol>
E8	Courant du moteur trop faible	<ol style="list-style-type: none"><li>1. Réinitialisation par mise hors tension puis sous tension du servomoteur.</li><li>2. Si l'erreur n'a pas pu être éliminée automatiquement après trois tentatives, contactez le service après-vente.</li></ol>
E9	Course trop longue dans un sens	<ol style="list-style-type: none"><li>1. Réinitialisation par mise hors tension puis sous tension du servomoteur.</li><li>2. Si l'erreur n'a pas pu être éliminée automatiquement après trois tentatives, contactez le service après-vente.</li></ol>

1

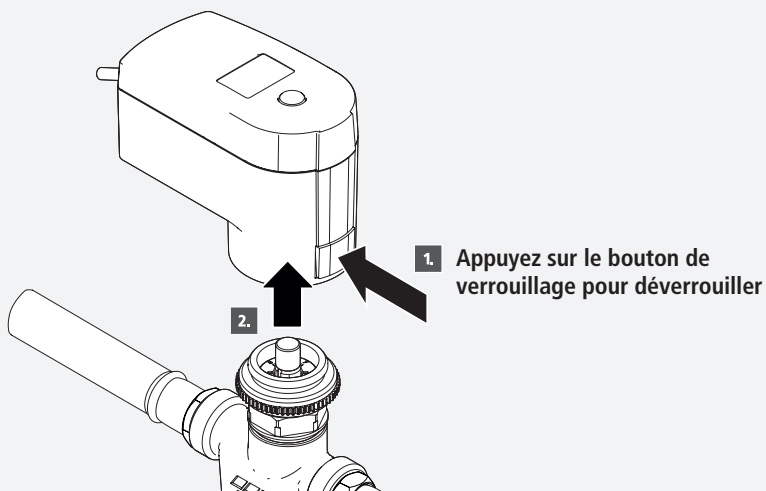

2

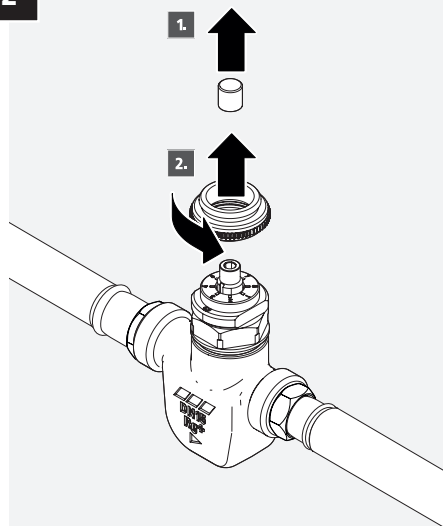

**Remarque!**  
Vérifiez si le capuchon de rallonge est encore monté et retirez-le.

3

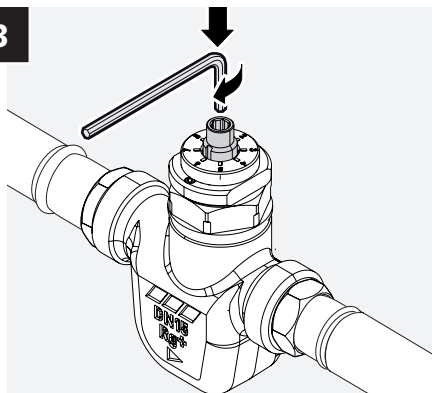

**Remarque!**  
Bloquer à la main uniquement à l'état monté!



**Remarque!**  
À l'ouverture, la broche doit être tournée complètement à gauche jusqu'à la butée pour que la fonction de régulation soit assurée!

# 8

## Entretien

1

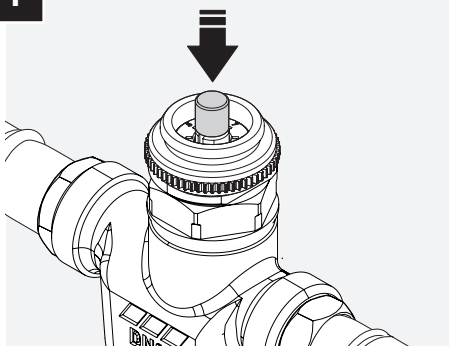

2

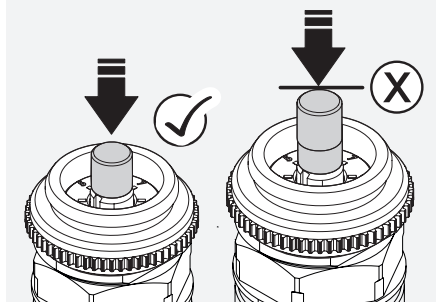

3

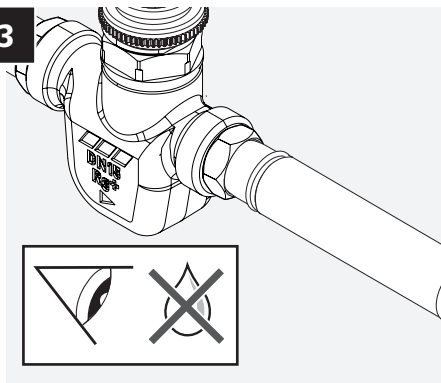

4

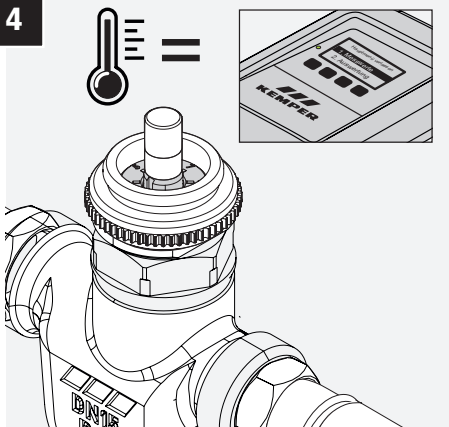

### Intervalle de maintenance

une fois par an

### 1–2: Enfoncer le robinet

L'enfoncement du robinet pendant le fonctionnement permet d'éliminer les dépôts et de nettoyer le robinet.

### 3: Contrôle visuel

Contrôlez l'absence de fuites.  
Remplacez le robinet en cas de fuite.

### 4: Contrôler la température

Contrôlez la température au niveau du régulateur.  
Vérifiez les températures au moyen du robinet de prélèvement.

### Contrôle du bon fonctionnement

Contrôlez la fonction de régulation, le cas échéant,  
la fonction de rinçage et la fonction d'arrêt.

### Contrôle de fonctionnement / réinitialisation du servomoteur

Contrôle à effectuer une fois monté.

**Démontage**

1. Si nécessaire, mettez le robinet hors tension.
2. Bloquez les tuyauteries.
3. Si nécessaire, démontez le servomoteur.
4. Desserrez les raccords à vis et séparez le robinet des tuyauteries.

**Mise au rebut**

Tenez compte des prescriptions locales relatives au recyclage et à l'élimination des déchets.

Ne jetez pas le produit dans les ordures ménagères, mais de manière adéquate.

Réf.	Pièces de rechange/Accessoires
4712701500	Coque isolante (accessoire)
6150000100	Servomoteur 230 V (pièce de rechange)
6150200100	Servomoteur 230 V (pièce de rechange neuve)
6160000100	Servomoteur 24 V (pièce de rechange)
6160200100	Servomoteur 24 V (pièce de rechange neuve)
6170G01500	KHS CoolFlow Robinet de régulation d'eau froide sans servomoteur

**Adaptateur de vanne correspondant**

Instruction du fabricant Kemper pour les Fig. 615 2G | 616 2G.

Adaptateur de vanne VA 80 – M30 x 1,5 8,5 mm

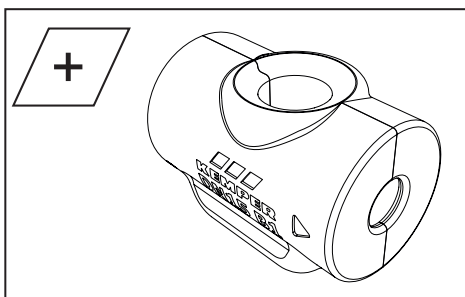
**Coque isolante**

Une coque isolante est disponible sous forme d'accessoire pour empêcher toute perte d'énergie, toute formation d'eau de condensation et toute contamination bactérienne.

DE	<b>Montage- und Bedienungsanleitung</b> KHS CoolFlow Kaltwasser-Regulierventil Fig. 615 0G   616 0G   617 0G	» 2
EN	<b>Operating instructions</b> KHS CoolFlow Cold water regulating valve Fig. 615 0G   616 0G   617 0G	» 21
FR	<b>Manuel d'utilisation</b> KHS CoolFlow Robinet de régulation d'eau froide Fig. 615 0G   616 0G   617 0G	» 41
IT	<b>Istruzioni per l'uso</b> KHS CoolFlow Valvola di regolazione dell'acqua fredda Fig. 615 0G   616 0G   617 0G	» 61
NL	<b>Bedieningshandleiding</b> KHS CoolFlow Koudwater-inregelafsluiter Fig. 615 0G   616 0G   617 0G	» 81

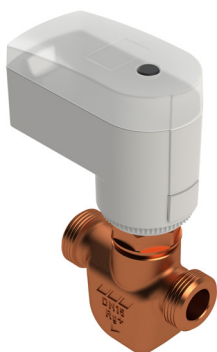

Fig. 615 2G

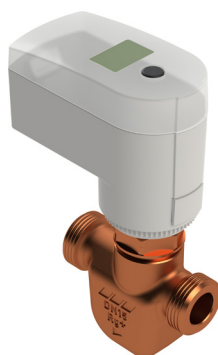

Fig. 616 2G



Fig. 615 0G | 616 0G | 617 0G



**Nota!**

Scansionare il codice QR per ottenere le istruzioni corrispondenti per queste varianti di prodotto.



[https://www.kemper-group.com/media/crossbase/dok\\_anl\\_k410061500001-00\\_sall\\_ain\\_v106.pdf](https://www.kemper-group.com/media/crossbase/dok_anl_k410061500001-00_sall_ain_v106.pdf)

## Indice

Avvertenze di sicurezza	63
1 Dati tecnici	64
2 Struttura e funzione	66
3 Regolazione	67
4 Montaggio	69
5 Collegamento elettrico	71
6 Indicatori di funzionamento	76
7 Chiusura manuale	78
8 Manutenzione	79
9 Smontaggio e smaltimento	80
10 Parti di ricambio e accessori	80

## Indirizzo del produttore

Gebr. Kemper GmbH + Co. KG  
Harkortstraße 5  
57462 Olpe  
Tel.: +49 2761 891-0

Web: [www.kemper-group.com](http://www.kemper-group.com)

## Servizio clienti

Hotline di assistenza

Tel.: +49 2761 891 800

E-mail: [anwendungstechnik@kemper-group.com](mailto:anwendungstechnik@kemper-group.com)

## Informazioni su queste istruzioni

Leggere con attenzione le presenti istruzioni prima di procedere al montaggio o all'utilizzo. Attenersi alle indicazioni fornite! Conservare queste istruzio-

## Approvazioni

ÜA



WRAS



ni per consultazione futura!

Le immagini riportate in queste istruzioni hanno lo scopo di agevolare la comprensione di base e possono differire dall'effettiva variante dell'impianto.

## Responsabilità

Il produttore non fornisce alcuna garanzia, né si assume alcuna responsabilità in caso di:

- mancata osservanza delle presenti istruzioni
- installazione e/o utilizzo errato
- modifica arbitraria del prodotto
- altro impiego non conforme

## Uso conforme

La valvola di regolazione dell'acqua fredda KHS CoolFlow (nel seguito la „valvola“) regola, risciacqua e chiude il circuito di circolazione dell'acqua potabile negli impianti dotati del sistema di igiene KHS. Qualunque altro utilizzo viene considerato come non conforme.

## Uso non conforme

Non utilizzare la valvola per la circolazione di sostanze diverse dall'acqua potabile e rispettare scrupolosamente i limiti d'impiego indicati nella sezione dei dati tecnici.



## Avvertenze di sicurezza

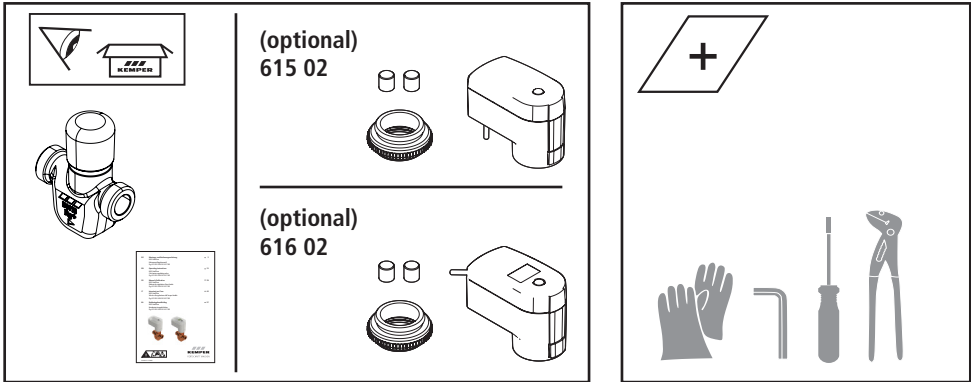

### Avvertenze di sicurezza

Attenersi scrupolosamente alle avvertenze di sicurezza riportate nelle istruzioni. La non osservanza delle avvertenze di sicurezza può causare la morte, lesioni o danni materiali. Indicatori delle avvertenze importanti:



#### Pericolo!

Indica i pericoli che possono avere come conseguenza lesioni gravi o mortali.



#### Attenzione!

Indica i pericoli che possono essere causa di lesioni, danni materiali o inquinamento dell'acqua potabile.



#### Nota!

Indica pericoli che possono essere causa di danni all'impianto o di malfunzionamenti.

### Fonti di pericolo



#### Pericolo!

Pericolo di morte per scossa elettrica!

- Prima di qualunque intervento, scollegare il sistema dall'alimentazione elettrica.



#### Attenzione!

Pericolo di lesioni per montaggio non corretto!

- Montaggio e manutenzione devono essere eseguiti esclusivamente da personale specializzato in impianti sanitari.



#### Attenzione!

Rischi per la salute derivanti da depositi presenti nei condotti!

- Dopo gli interventi di montaggio e manutenzione sciacquare sempre i condotti conformemente alle norme DIN EN 806-5 e VDI/DVGW 6023 (v. capitolo 7, figure 1-2).



#### Nota!

Danni materiali dovuti a temperature troppo alte durante la disinfezione termica!

- Smontare la valvola di regolazione per di eseguire una disinfezione termica e inserire un raccordo.

Durante il montaggio:  
attenersi alle norme  
DIN EN 806 | DIN EN 1717 | DIN 1988

## Dati tecnici

	N. art.	Variante	Funzione
	615 2G	Con attuatore 230 V	Per sistema master/slave
	616 2G	Con attuatore 24 V	Per BMS con riscontro posizione
	617 0G	Senza attuatore	Nessuna funzione di risciacquo

Grandezza	Valore	Unità
Campo di regolazione	da 15 a 22	°C
Livello di pressione	10	PN
Massima temperatura di esercizio liquido	50	°C
Kv min. - v. capitolo 3	0,03	m <sup>3</sup> /h
Kv max. - v. capitolo 3	1,72	m <sup>3</sup> /h
Kv risciacquo (solo con attuatore) - v. capitolo 3	2,2	m <sup>3</sup> /h
Diametro nominale collegamenti	15	DN
Dimensioni (H x L x L, con attuatore)	156,5 x 90 x 45	mm
Dimensioni (H x L x L, senza attuatore)	91,5 x 73 x 31	mm

## 1

## Dati tecnici

Attuatore	Fig. 615 2G (230 V)	Fig. 616 2G (24 V)	
Tensione di alimentazione	230 V AC (50 Hz)	24 V AC (50/60 Hz)	24 V DC
Potenza assorbita dimensionamento	5,8 VA	4,4 VA	1,9 W
Potenza assorbita nominale	3,5 VA	2,0 VA	1,0 W
Massima corrente di entrata	durata breve max. 10 A		
Lunghezza cavo di collegamento	1,0 m		
Sezione cavo	3 x 0,75 mm <sup>2</sup>	4 x 0,22 mm <sup>2</sup>	
Massima temperatura ambiente	50 °C		
Massima umidità ambiente	0 - 85 % (senza condensa)		
Categoria di sovratensione	II	III	
Forza di attuazione	200 N		
Grado di inquinamento	2		
Classe di protezione secondo EN 60730	2	3	
Massima alzata valvola	8,5 mm (Messaggio di errore e corse di regolazione leggibili attraverso i LED colorati)	8,5 mm (è possibile leggere la posizione e la tensione di controllo applicata)	
Tempo di attuazione	15 s/mm		
Visualizzazione	LED multicolore	LED multicolore e LCD	

**Nota!**

Il tempo minimo di un ciclo con funzionamento a 3 punti è di  $\geq 2$  secondi.  
Se l'azionamento viene regolato con un tempo di accensione più breve,  
non è garantita una corretta disattivazione.

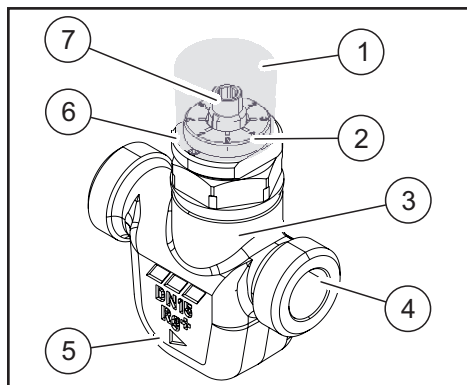

- |   |   |
|---|---|
| 1 | Tappo di sicurezza                        |
| 2 | Indicazione di posizione                  |
| 3 | Alloggiamento valvola                     |
| 4 | Raccordi per tubi                         |
| 5 | Indicazione direzione del flusso          |
| 6 | Supporto motore / regolazione temperatura |
| 7 | Regolazione temperatura/mandrino          |
| 8 | Tappo di regolazione                      |

### Funzione

La posizione della valvola ne determina la funzione.

1. Funzione di regolazione: la funzione di regolazione termica crea un equilibrio idraulico automatico nel sistema di circolazione dell'acqua fredda.
2. Funzione di risciacquo: la funzione di risciacquo crea una corrente turbolenta in tutte le aree dell'impianto di acqua potabile.
3. Funzione di arresto: La funzione di arresto elettrico viene utilizzata per chiudere tutte le valvole di regolazione dell'acqua fredda installate. Durante un processo di risciacquo, tutte le valvole di regolazione dell'acqua fredda sono chiuse ad eccezione di quelle relative al risciacquo. La funzione di risciacquo (2.) può ora essere eseguita sulla valvola di regolazione dell'acqua fredda rilevante per il risciacquo. Il sistema può essere spento da un punto centrale come descritto per eseguire il processo di lavaggio uno dopo l'altro.

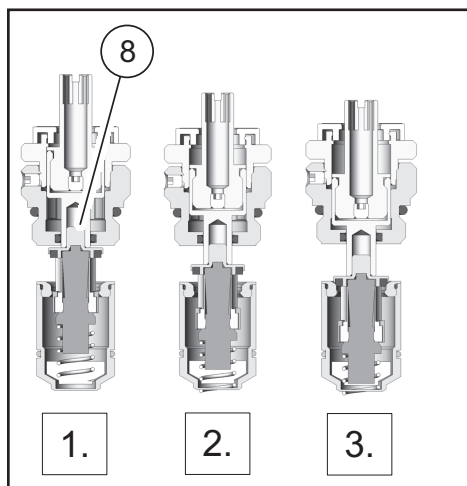
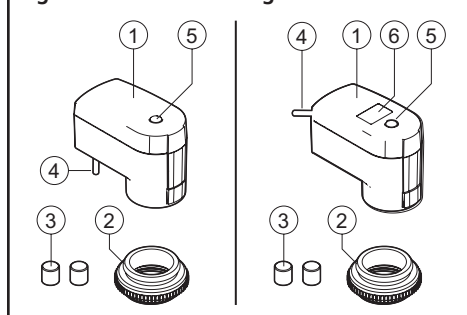

Fig. 615 02

Fig. 616 02



### Attuatore

L'attuatore permette di utilizzare la funzione di risciacquo.

- |   |  |
|---|--|
| 1 | Alloggiamento attuatore                          |
| 2 | Adattatore per valvola VA 80 - M30 x 1,5 8,5 mm  |
| 3 | Tappo di prolunga (1 come ricambio in dotazione) |
| 4 | Cavo di collegamento                             |
| 5 | Display a LED                                    |
| 6 | Display LC con indicatore di stato               |

## 2

## Struttura e funzione

### Ambiente di esercizio

La valvola di regolazione è concepita per essere utilizzata in impianti di acqua potabile con il sistema di igiene KHS CoolFlow. Può essere integrata in nuovi impianti KHS

oppure può essere aggiunta a impianti KHS esistenti. L'integrazione in un sistema di igiene esistente è possibile grazie al controllo in modalità master/slave o BMS.

## 3

## Regolazione

1

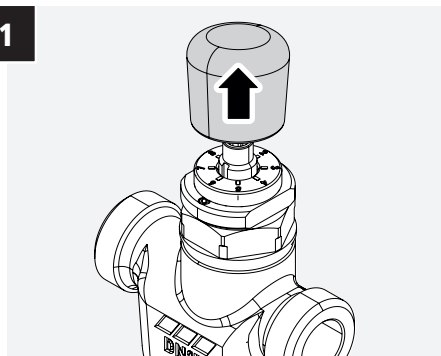

2

Svitare

Nota!  
Impostazione di fabbrica 3!

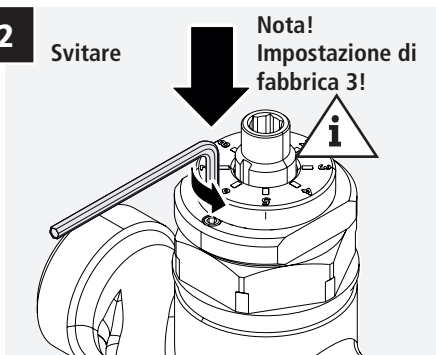

3

Pag. 68  
Intervallo  
di regolazione



Indicatore di  
posizione

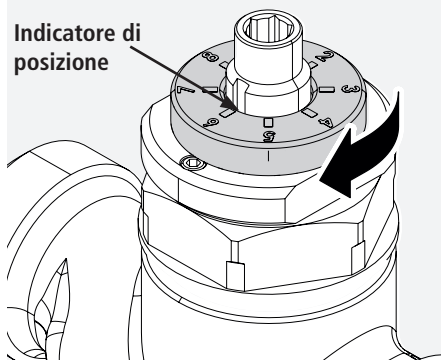

4

Fissare

Nota! Ruotare il  
mandrino verso  
destra fino  
all'arresto!

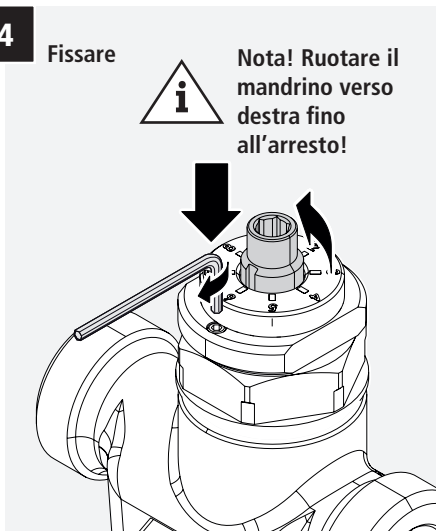

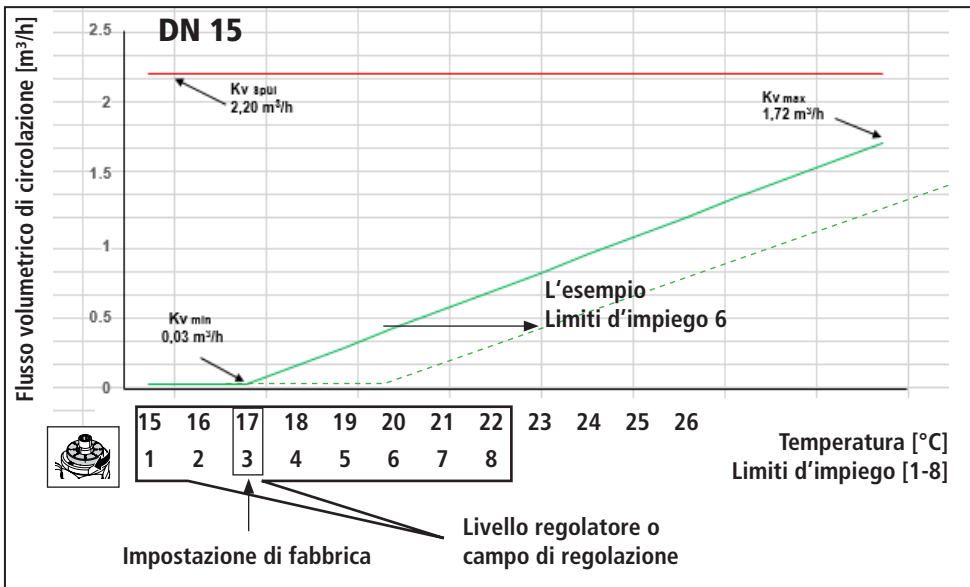
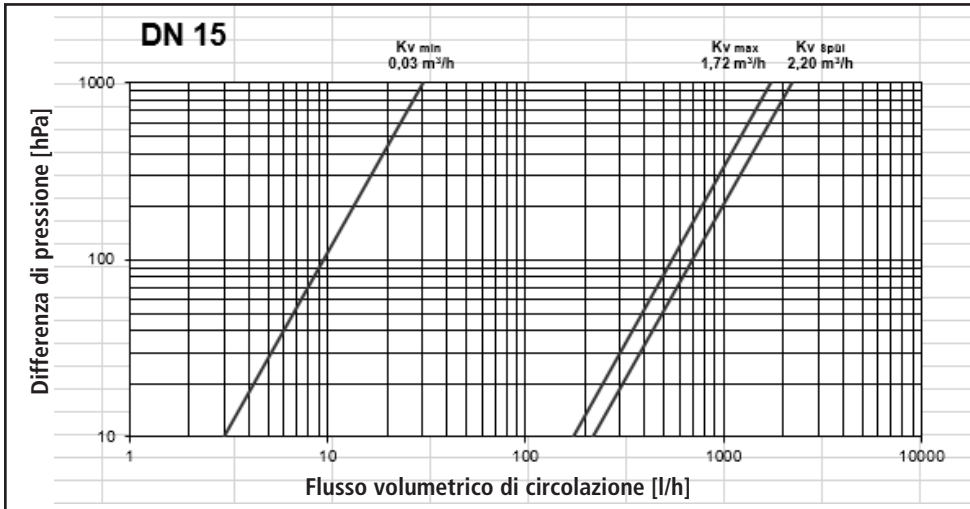

# 4

## Montaggio

1



**Nota!**  
Rispettare le dimensioni  
d'ingombro!

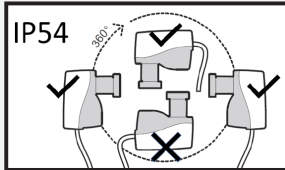

96 mm

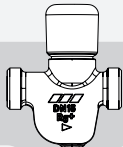

113 mm



70 mm

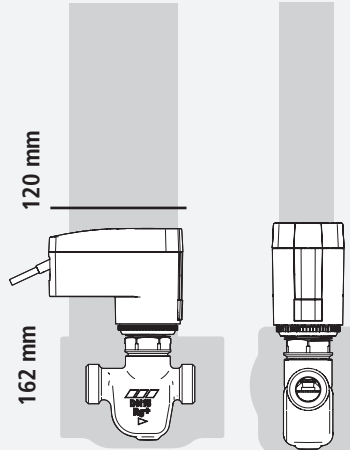

120 mm

162 mm

113 mm

70 mm

2

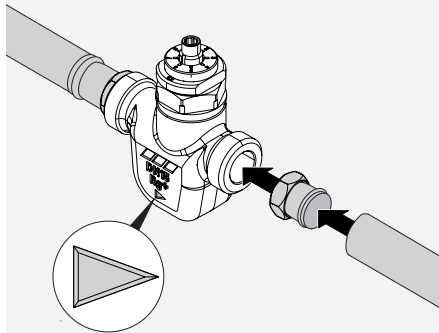

**Nota!**  
Prestare attenzione alla  
direzione del flusso!  
Montare la tubazione diritta!

3



**Nota!**  
Le fasi di lavoro seguenti si  
applicano alle versioni 615  
2G e 616 2G.

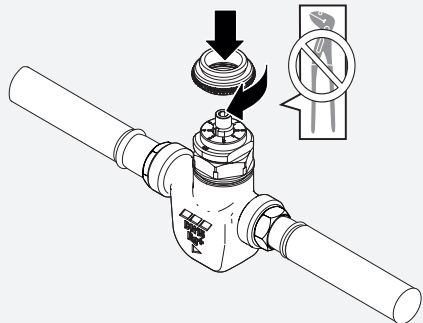

4

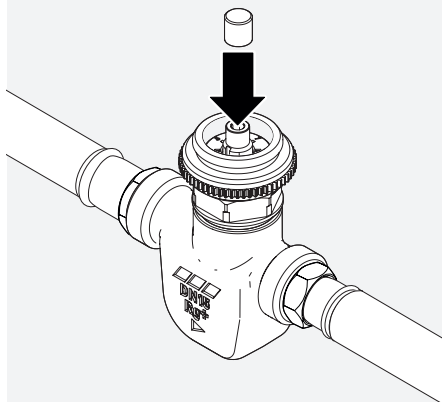

**Nota!**  
La fornitura comprende  
un tappo di prolunga di  
ricambio.

5

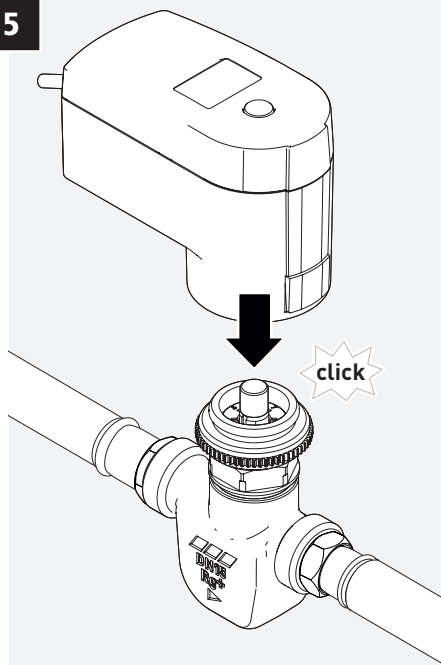

6

Fig. 615 2G (versione 24 V)

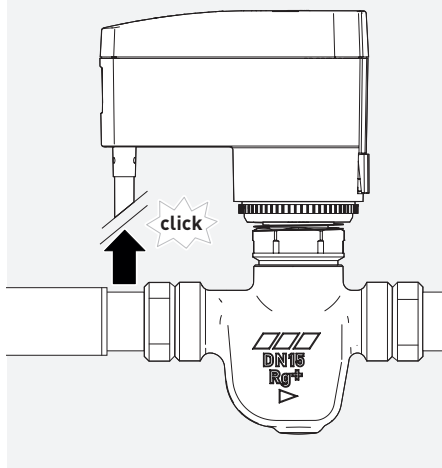

7

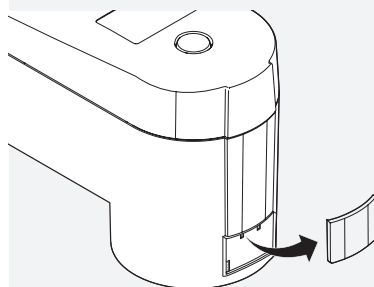

**Nota!**  
Rimuovendo il perno di  
bloccaggio si protegge il  
dispositivo dallo smontaggio  
da parte di persone non  
autorizzate.

1

**Pericolo!****Scossa elettrica! Mantenere asciutto l'ambiente!****Prima di aprire l'alloggiamento mettere l'impianto fuori tensione!****Nota!**

La Fig. 615 2G e la Fig. 615 02 possono essere apprese solo con il software dell'apparecchio MASTER 2.1 superiore alla V2.23.15. Inoltre, è necessario configurare il tipo di valvola corrispondente „KHS CoolFlow V2.0“!



**Collegamento 230V:**  
Fig. 686 02 008

[1] → br (BN)  
[2] → sw (SW)  
[3] → gr (GR)

**Nota! Collegamento 230 V solo in abbinamento al mini- dispositivo di controllo KHS MASTER 2.1 o al mini-dispositivo di controllo SLAVE.**

**Nota!**

**È necessario garantire una sufficiente soppressione delle interferenze nel condotto di alimentazione dell'azionamento.**

L'attuatore a 3 punti da 230 V viene controllato tramite il pannello di controllo del sistema KHS mini MASTER 2.1. Per l'installazione di un sistema a 230 V si consigliano i seguenti cavi:

- Cavo inguainato: NYM 5x1,5 mm<sup>2</sup>
- Piattina: NYIF 5x1,5mm<sup>2</sup>

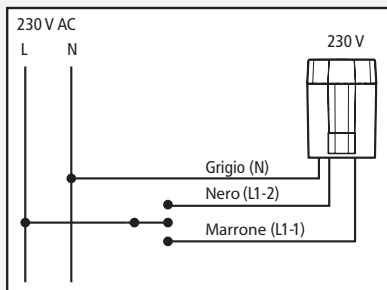

Funzione	Descrizione
Grigio (N)	Conduttore neutro
Tensione su nero (L1-2)	La piastra di pressione della valvola si ritrae
Tensione su marrone (L1-1)	La piastra di pressione della valvola si estende
Nessuna tensione su marrone e nero	La piastra di pressione della valvola rimane nella posizione attuale

## 1

**Inizializzazione:**

Dopo l'accensione dell'alimentazione di tensione, la valvola di regolazione dell'acqua fredda KHS CoolFlow Fig. 616 2G esegue un'inizializzazione proporzionale. Nella fase di inizializzazione, l'attuatore determina la distanza di traslazione e visualizza „In“ (per l'inizializzazione) sul display. Allo stesso tempo il LED verde lampeggia.

In primo luogo, la piastra di pressione della valvola viene completamente retratta, determinando così il fincorsa interno dell'attuatore. La piastra di pressione della valvola si estende e, durante il percorso, determina innanzitutto la posizione di contatto con la punteria della valvola e il secondo fincorsa, quando viene raggiunta la fine del percorso della valvola e il servomotore si è fermato.

La fine dell'inizializzazione è segnalata dallo spegnimento del LED verde, della scritta „In“ sul display e dalla comparsa alternata della tensione di controllo applicata e della posizione di regolazione attuale.

**Nota!**

Per una fase di inizializzazione, la valvola di regolazione dell'acqua fredda KHS CoolFlow Fig. 616 2G necessita in proporzione di max. 7 min.; durante l'inizializzazione l'attuatore non reagisce alla tensione di controllo applicata.

**Funzionamento**

L'attuatore a 24 V viene controllato tramite un segnale di comando da 0 a 10 VCC proveniente dalle apparecchiature di controllo per edifici. Il segnale di comando consente di controllare e posizionare con precisione l'attuatore. In alternativa, è possibile applicare un segnale PWM all'ingresso della tensione di controllo, vedere il diagramma:

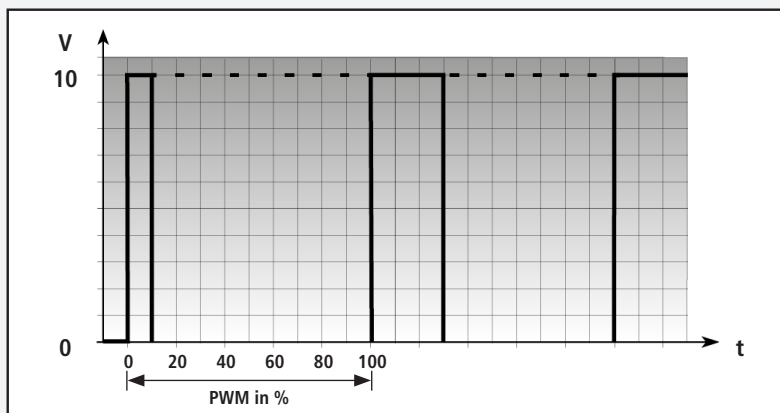

### Frequenza dell'ampiezza dell'impulso da 100 Hz a 1000 Hz

Dopo l'inizializzazione, la tensione di controllo applicata viene convertita proporzionalmente in una posizione di controllo. L'attuatore utilizza la tensione di controllo, la corsa di regolazione impostata o la distanza di traslazione misurata (a seconda della modalità) per calcolare la posizione di controllo da raggiungere e si sposta con precisione in questa posizione.



#### Nota!

- 0 V l'intera punteria della valvola è in estensione
- 4,6 V punteria della valvola in posizione di scarico
- 10 V punteria completa della valvola retratta

#### Azionamento CoolFlow 24 V attuatore

Funzione	Tensione	Descrizione
1 Funzione di regolazione	10 V	Regolazione della valvola
2 Funzione di risciacquo	4,6 V	Sciacquoni delle valvola (+/- 0,5 V Kv risciacquo)
3 Funzione di chiusura	0 V	Valvola chiusa

## 2

**Segnale di feedback**

Il segnale di feedback dell'attuatore a 24 V consente un riscontro diretto dello stato di funzionamento attuale al sistema DDC tramite un segnale da 0 a 10 V. Le tensioni da 1 a 9 volt forniscono informazioni sulla posizione dell'attuatore, mentre le tensioni < 0,5 V e > 9,5 V segnalano errori che si sono verificati. Il collegamento del segnale di feedback è a prova di tensione fino a 24 V.

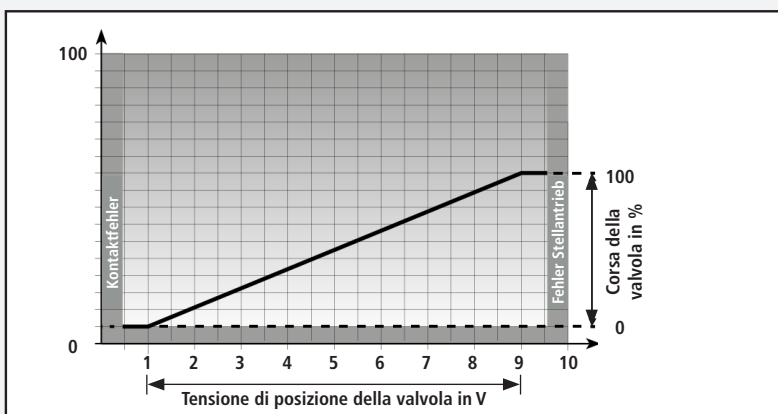

## Collegamento elettrico attuatore 24 V CA/CC, L1 (+) L2 (-)

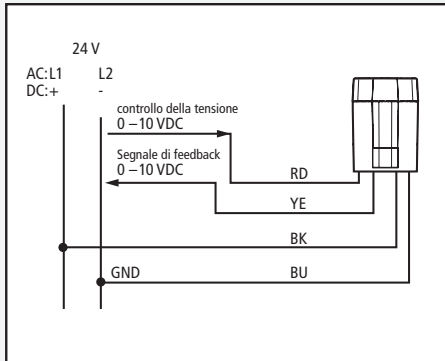
**Cavo di collegamento**

Per l'installazione di un sistema a 24 V sono consigliate le seguenti lunghezze massime dei cavi:

Gestione	Sezione trasversale	lunghezza
Cavo DCC standard	0,22 mm <sup>2</sup>	20 m
J-Y(ST)Y	0,8 mm <sup>2</sup>	45 m
NYM / NYIF	1,5 mm <sup>2</sup>	136 m

**Trasformatore/alimentatore**

È necessario utilizzare un trasformatore di sicurezza conforme alla norma EN 61558-2-6 o un alimentatore a commutazione conforme alla norma EN 61558-2-16.

**Indicatori di funzionamento tramite LED**

Per la segnalazione del funzionamento degli stati operativi, il Motoric Valve Drive è dotato di: attuatore a 3 punti da 230 V tramite un LED multicolore. Come colori di segnalazione vengono utilizzati il verde, l'arancione e il rosso. La segnalazione avviene solo quando l'attuatore è alimentato con la tensione di esercizio. Il LED si accende circa 3 secondi dopo l'accensione per evitare che lampeggi durante il controllo degli impulsi.

Se l'azionamento si muove contro il fincorsa superiore o inferiore, il motore si spegne dopo il superamento del tempo assegnato, così come il LED.

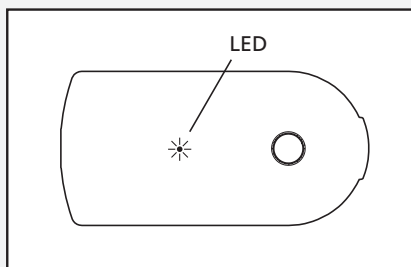

Segnale LED	Significato
rosso	Caso di errore
verde	La piastra di pressione della valvola si ritrae
arancione	La piastra di pressione della valvola si estende

**Display LCD | vale solo per la Fig. 616 2G**

Il display LCD dell'attuatore a 24 V visualizza alternativamente la posizione di controllo e la tensione di controllo applicata. Quando viene effettuata una richiesta di controllo, la direzione di marcia corrente è indicata da una freccia sul display LCD. In caso di errore, il codice di errore corrispondente viene visualizzato e segnalato dal LED rosso sempre acceso.

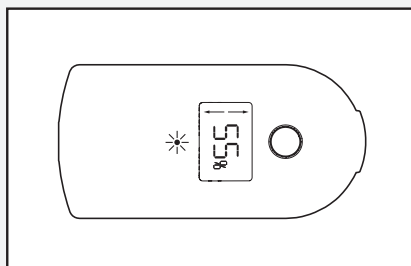

**Codici di errore | vale solo per la Fig. 616 2G**

Gli errori sono segnalati da un codice di errore. La tabella seguente spiega i vari codici di errore e le relative correzioni.

Codice di errore	Descrizione	Correzione degli errori
E7	Blocco durante la corsa di inzializzazione in posizione non autorizzata	<ol style="list-style-type: none"> <li>1. Scollegare l'attuatore dall'alimentazione</li> <li>2. Spostare l'albero di posizionamento dalla posizione finale con il regolatore manuale</li> <li>3. Nuova inzializzazione dopo la riaccensione della tensione. Se l'errore si ripete contattare il servizio clienti.</li> </ol>
E8	Corrente del motore troppo bassa	<ol style="list-style-type: none"> <li>1. Nuova inzializzazione mediante spegnimento e accensione dell'attuatore.</li> <li>2. Se non è stato possibile eliminare automaticamente l'errore dopo massimo tre tentativi, è necessario rivolgersi al servizio clienti.</li> </ol>
E9	Spostamento troppo lungo in una direzione	<ol style="list-style-type: none"> <li>1. Nuova inzializzazione mediante spegnimento e accensione dell'attuatore.</li> <li>2. Se non è stato possibile eliminare automaticamente l'errore dopo massimo tre tentativi, è necessario rivolgersi al servizio clienti.</li> </ol>

## Chiusura manuale

1

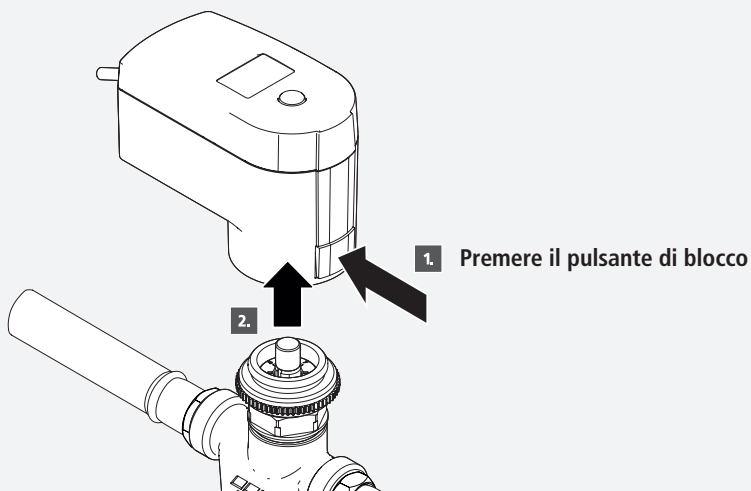

2

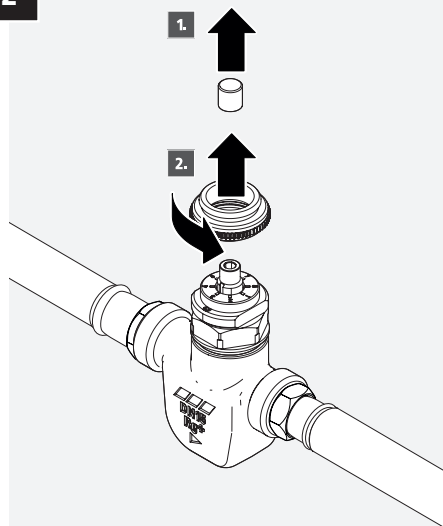

**Nota!**  
Controllare se il tappo di prolunga è ancora montato e rimuoverlo.

3

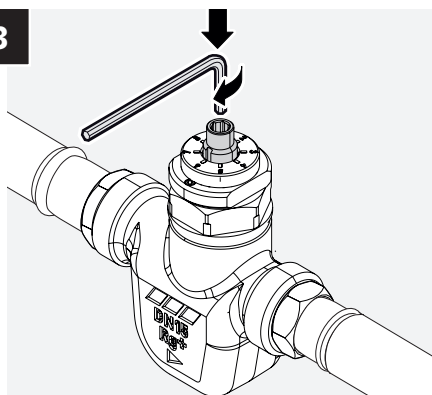

**Nota!**  
Chiudere a mano solo quando assemblato!



**Nota!**  
All'apertura successiva, il mandrino deve essere completamente ruotato verso sinistra fino all'arresto in modo da ottenere di nuovo la funzione di regolazione!

# 8

## Manutenzione

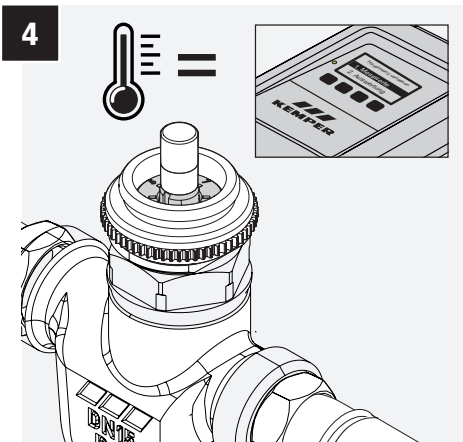
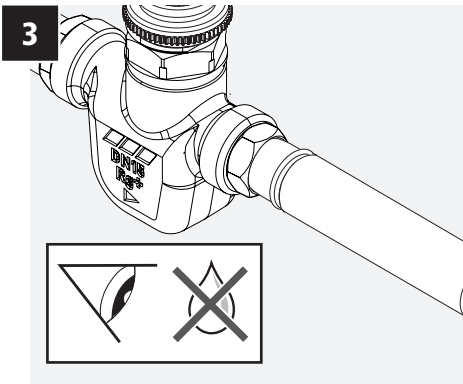
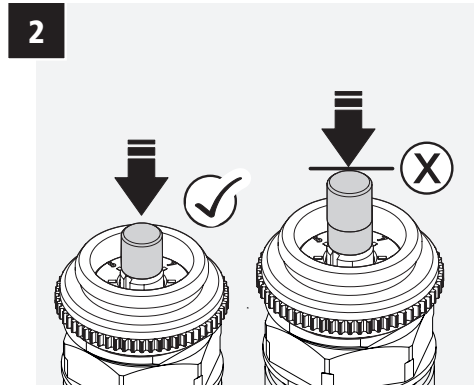
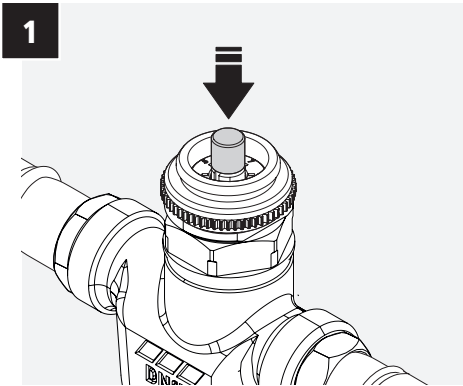

### Intervali di manutenzione

1 volta all'anno

#### 1-2: Premere la valvola

Spingere la valvola in basso mentre è in funzione per eliminare eventuali depositi e pulire la valvola.

#### 3: Controllo visivo

Verificare se ci sono perdite.

In caso di perdite, sostituire la valvola.

#### 4: Controllare la temperatura

Verificare la temperatura sul regolatore.

Controllare le temperature tramite il rubinetto di prelievo.

#### Verifica del funzionamento

Controllare la funzione di regolazione, di risciacquo e di chiusura.

#### Verifica del funzionamento/ reinizializzazione attuatore

Verifica a montaggio completato.

## Smontaggio e smaltimento

### Smontaggio

1. Se necessario, scollegare la valvola dalla corrente elettrica.
2. Chiudere i condotti.
3. Eventualmente smontare l'attuatore.
4. Allentare i raccordi a vite e separare la valvola dai condotti.



### Smaltimento

Attenersi alle disposizioni locali in materia di riciclo e smaltimento dei rifiuti.

Non smaltire il prodotto con i rifiuti domestici, ma in modo corretto.

## 10

## Parti di ricambio e accessori

N. ordine	Parte di ricambio/Accessorio
4712701500	Rivestimento isolante (accessorio)
6150000100	Attuatore 230 V (parte di ricambio)
6150200100	Attuatore 230 V (Nuovo pezzo di ricambio)
6160000100	Attuatore 24 V (parte di ricambio)
6160200100	Attuatore 24 V (Nuovo pezzo di ricambio)
6170G01500	KHS CoolFlow Valvola di regolazione dell'acqua fredda senza attuatore

### Adattatore per valvola idoneo

Specifiche del produttore Kemper per

Fig. 615 2G I 616 2G.

Adattatore per valvola VA 80 - M30 x 1,5 8,5 mm

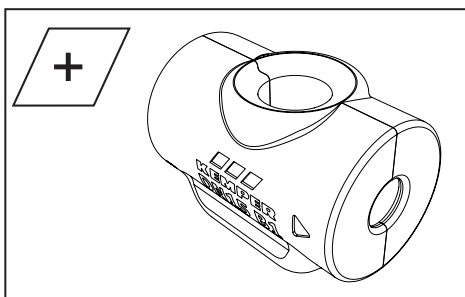

### Rivestiment

È disponibile come accessorio

un rivestimento isolante che ostacola la perdita di energia, la formazione di condensa e di germi.

DE	<b>Montage- und Bedienungsanleitung</b> KHS CoolFlow Kaltwasser-Regulierventil Fig. 615 0G   616 0G   617 0G	» 2
EN	<b>Operating instructions</b> KHS CoolFlow Cold water regulating valve Fig. 615 0G   616 0G   617 0G	» 21
FR	<b>Manuel d'utilisation</b> KHS CoolFlow Robinet de régulation d'eau froide Fig. 615 0G   616 0G   617 0G	» 41
IT	<b>Istruzioni per l'uso</b> KHS CoolFlow Valvola di regolazione dell'acqua fredda Fig. 615 0G   616 0G   617 0G	» 61
NL	<b>Bedieningshandleiding</b> KHS CoolFlow Koudwater-inregelafsluiter Fig. 615 0G   616 0G   617 0G	» 81

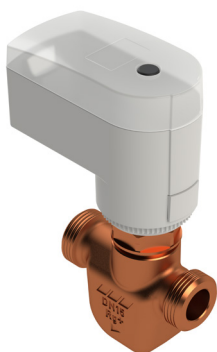

Fig. 615 2G

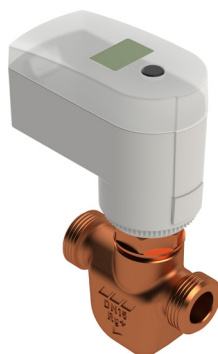

Fig. 616 2G



Fig. 615 0G | 616 0G | 617 0G

**Opmerking!**

Scan de QR-code om bijbehorende instructies te krijgen voor deze productvarianten.

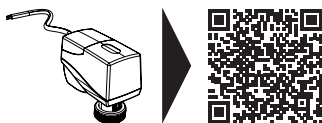

[https://www.kemper-group.com/media/crossbase/dok\\_anl\\_k410061500001-00\\_sall\\_ain\\_v106.pdf](https://www.kemper-group.com/media/crossbase/dok_anl_k410061500001-00_sall_ain_v106.pdf)

**Certificaat**

ÜA



WRAS

**Inhoudsopgave**

Veiligheidsinstructies	83
1 Technische gegevens	84
2 Opbouw en werking	86
3 Instelling	87
4 Montage	89
5 Elektrische aansluiting	91
6 Functieweergaven	96
7 Handmatig afsluiten	98
8 Instandhouding	99
9 Demontage en afvalverwijdering	100
10 Reservedelen en toebehoren	100

**Adres fabrikant**

Gebr. Kemper GmbH + Co. KG

Harkortstraße 5

D-57462 Olpe

Tel.: +49 2761 891-0

Web: [www.kemper-group.com](http://www.kemper-group.com)

**Klantenservice**

Servicehotline

Tel.: +49 2761 891 800

E-mail: [anwendungstechnik@kemper-group.com](mailto:anwendungstechnik@kemper-group.com)

**Over deze handleiding**

Lees deze handleiding voor de installatie of ingebruikname zorgvuldig door en volg de instructies op! Bewaar deze handleiding goed, zodat u haar

later weer kunt raadplegen.

Afbeeldingen in deze handleiding dienen de basis-kennis en kunnen afwijken van de daadwerkelijke uitvoering.

**Aansprakelijkheid**

De fabrikant verleent geen garantie en stelt zich niet aansprakelijk bij:

- het niet in acht nemen van deze handleiding;
- incorrecte inbouw en/of gebruik;
- eigenhandige wijziging van het product;
- andere, onjuiste bediening.

**Doelmatig gebruik**

De KHS CoolFlow koudwater-inregelafsluiter (hierna 'afsluiter' genoemd) regelt, spoelt en sluit de drinkwatercirculatiecircuits in installaties met hygiënesysteem KHS. Ieder ander gebruik geldt als ondoelmatig.

**Verkeerd gebruik**

Gebruik de afsluiter niet voor de circulatie van andere stoffen dan drinkwater en alleen binnen de grenzen van de in de technische gegevens vermelde toepassingsgrenzen.



## Veiligheidsinstructies

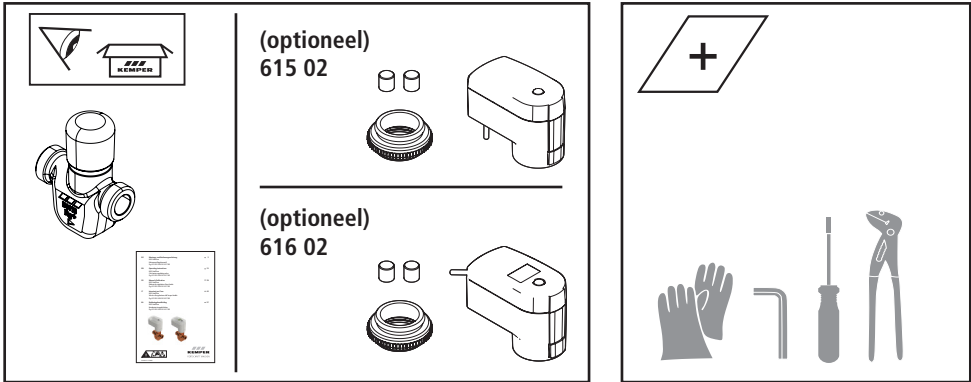

### Veiligheidsinstructies

Neem de veiligheidsinstructies in de handleiding in acht en volg ze op. Het niet in acht nemen van de veiligheidsinstructies kan leiden tot de dood, letsel of materiële schade.

Markering belangrijke waarschuwingen:



#### **Gevaar!**

Duidt op gevaren die ernstig of dodelijk letsel tot gevolg kunnen hebben.



#### **Waarschuwing!**

Geeft de gevaren aan die tot letsel, materiële schade of verontreiniging van het drinkwater kunnen leiden.



#### **Opmerking!**

Markeert gevaren die tot schade aan de installatie of tot storingen tijdens het functioneren kunnen leiden.

### Gevarenbronnen



#### **Gevaar!**

Levensgevaarlijk door elektrische stroom!

Schakel het systeem voor werkzaamheden eraan spanningsvrij.



### **Waarschuwing!**

Letselgevaar door onvakkundige montage!

Montage en onderhoud mogen alleen door een loodgieter worden uitgevoerd.



### **Waarschuwing!**

Gevaar voor de gezondheid door residuen in leidingen!



Spoel de leidingen na montage en onderhoud altijd door volgens EN 806-5 en VDI/DVGW 6023 (zie hoofdstuk 7 Afbeelding 1-2).



### **Opmerking!**

Materiële schade door te hoge temperaturen bij thermische desinfectie! Demonteer de inregelafsluiter tijdens u een thermische desinfectie uitvoert en plaats een fitting.

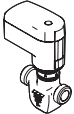
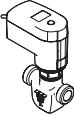
Bij de montage in acht nemen:  
EN 806 | EN 1717 | DIN 1988

	Figuur- nummer	Productvariant	Werking
	615 2G	Met servomotor 230 V	Voor master/slave-systeem
	616 2G	Met servomotor 24 V	Voor GBS met positieterugkoppelingssignaal
	617 0G	Zonder servomotor	Geen spoelfunctie

Grootte	Waarde	Eenheid
Instelbereik	15 tot 22	°C
Drukniveau	10	PN
Max. bedrijfstemperatuur medium	50	°C
kV-min - zie hoofdstuk 3	0,03	m <sup>3</sup> /h
kV-max - zie hoofdstuk 3	1,72	m <sup>3</sup> /h
kV-spoel (alleen met servomotor) - zie hoofdstuk 3	2,2	m <sup>3</sup> /h
Nominale diameter aansluitingen	15	DN
Afmetingen (h x l x b, met servomotor)	156,5 x 90 x 45	mm
Afmetingen (h x l x b, zonder servomotor)	91,5 x 73 x 31	mm

## 1

## Technische gegevens

Servomotor	Fig. 615 2G (230 V)		Fig. 616 2G (24 V)	
	Voedingsspanning	230 V AC (50 Hz)		24 V AC (50/60 Hz)
Opgenomen vermogen dimensionering	5,8 VA		4,4 VA	1,9 W
Nominaal opgenomen vermogen	3,5 VA		2,0 VA	1,0 W
Max. inschakelstroom	kortstondig max. 10 A			
Lengte aansluitkabel	1,0 m			
Kabeldikte	3 x 0,75 mm <sup>2</sup>		4 x 0,22 mm <sup>2</sup>	
Max. omgevingstemperatuur	50 °C			
Max. omgevingsvochtigheid	0 - 85 % (niet condenserend)			
Overspanningscategorie	II		III	
Instelkracht	200 N			
Verontreinigingsgraad	2			
Beschermingsniveau EN 60730	2		3	
Max. slaglengte afsluiter	8,5 mm (foutmelding en instelprocedures via led kleuren)		8,5 mm (positie en aanwezige stuurspanning kan worden afgelezen)	
Insteltijd	15 s/mm			
Weergave	Led meerdere kleuren		Led meerdere kleuren & lcd	

**Opmerking!**

De minimale kloktijd in 3-puntsbedrijf bedraagt 2 seconden. Als de aandrijving met een kortere inschakeltijd geklokt wordt, kan een correcte uitschakeling niet worden gewaarborgd.

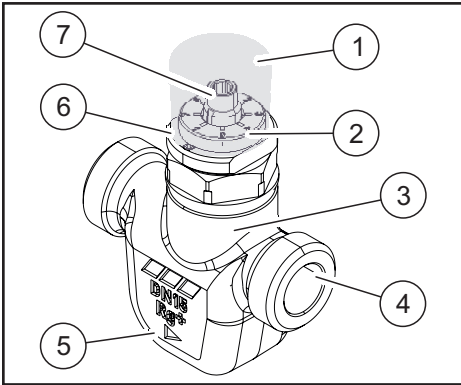

- |   |                                      |
|---|--------------------------------------|
| 1 | Beschermkap                          |
| 2 | Positie-indicator                    |
| 3 | Behuizing afsluiter                  |
| 4 | Buisaansluitingen                    |
| 5 | Weergave stroomrichting              |
| 6 | Motorhouder / temperatuurverstelling |
| 7 | Spindel / temperatuurverstelling     |
| 8 | Regelkegel                           |

### Werking

De positie van de afsluiter bepaalt de werking.

1. **Reguleerfunctie:** De thermische reguleerfunctie zorgt voor een automatische hydraulische balans van het koudwatercirculatiesysteem.
2. **Spoelfunctie:** De spoelfunctie maakt een turbulente doorstroming door alle delen van de drinkwaterinstallatie mogelijk.
3. **Afsluitfunctie:** De elektrische afsluitfunctie wordt gebruikt om alle geïnstalleerde koudwater regelafsluiters af te sluiten. Tijdens een spoelproces worden alle koudwater regelafsluiters afgesloten, behalve de regelafsluiter die van belang is voor het spoelen. De spoelfunctie (2.) kan nu worden uitgevoerd op het voor de spoeling van belang zijnde regelafsluiter voor koud water. Het systeem kan vanaf een centraal punt worden afgesloten, zoals beschreven, om het spoelproces na elkaar uit te voeren.

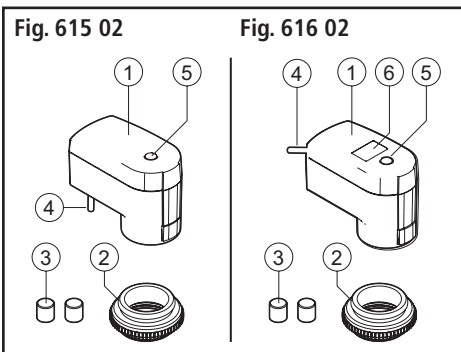
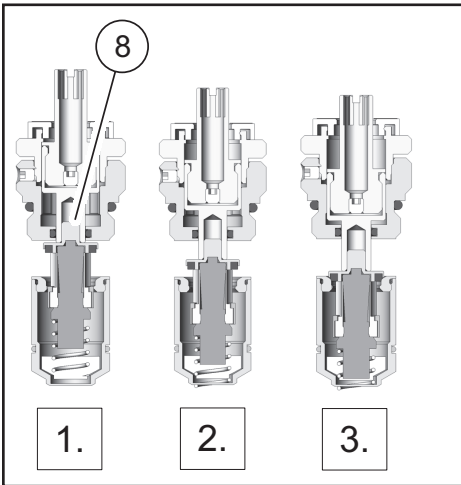

### Servomotor

De servomotor maakt de spoelfunctie mogelijk.

- |   |   |
|---|---|
| 1 | Behuizing servomotor                                    |
| 2 | Ventieladapter VA 80 - M30 x 1,5 8,5 mm                 |
| 3 | Verlengkap<br>(1x als vervanging in de leveringsomvang) |
| 4 | Aansluitkabel   |
| 5 | Ledindicatie  |
| 6 | Lc-display met statusindicatie                          |

## 2

## Opbouw en werking

### Toepassingsomgeving

De inregelafsluiter is bedoeld voor gebruik in drinkwaterinstallaties met het hygiënesysteem KHS CoolFlow. Het kan worden toegepast in nieuwe KHS-installaties en kan achteraf in

bestaande KHS-installaties worden ingebouwd. Integratie in bestaande hygiënesystemen is mogelijk door de besturing via master/slave of GBS.

## 3

## Instelling

1

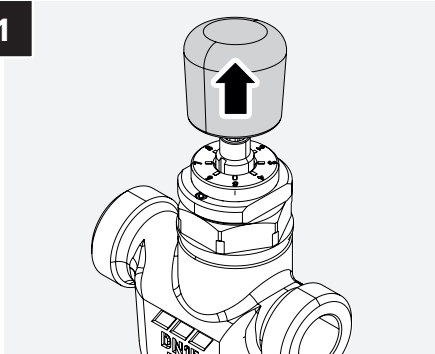

2

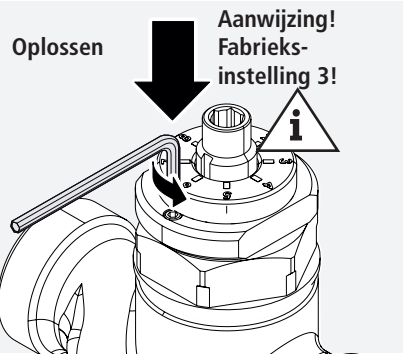

3

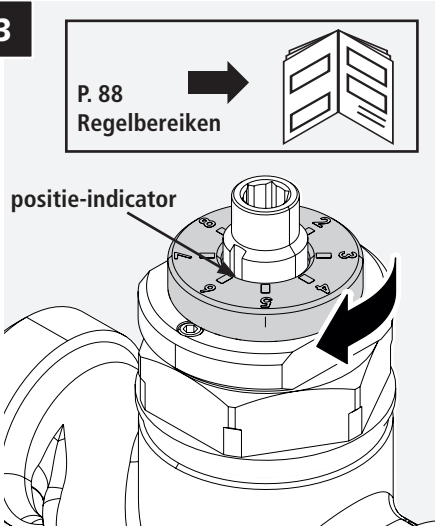

4

Afmeren

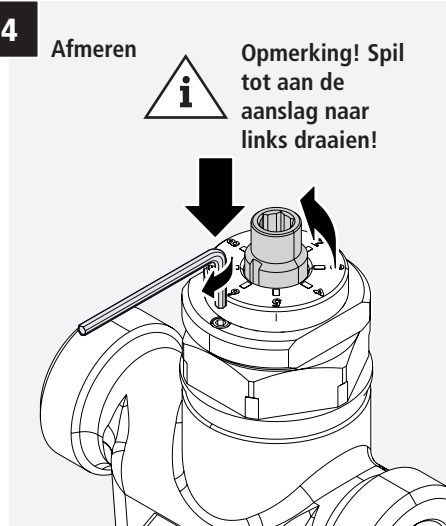

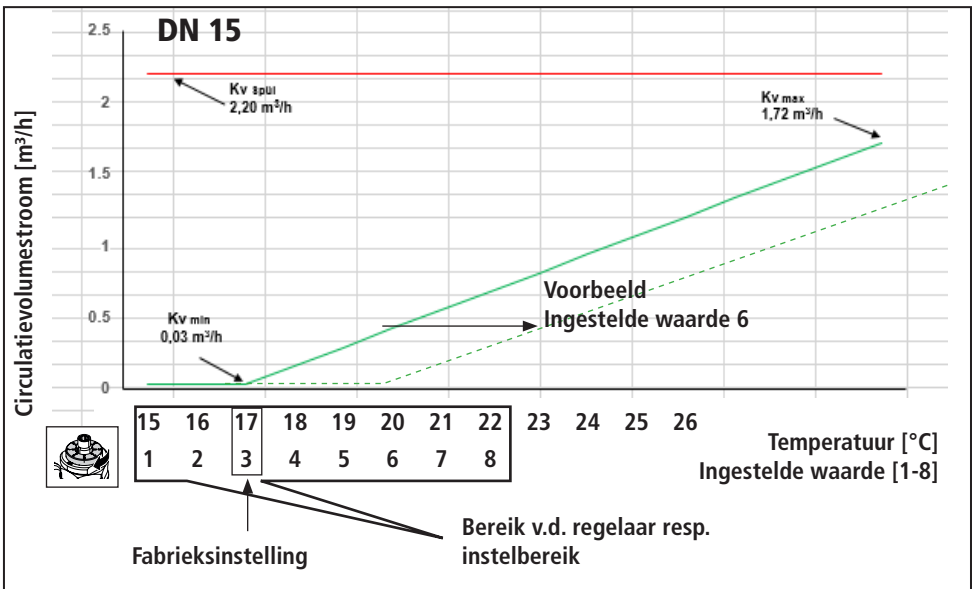
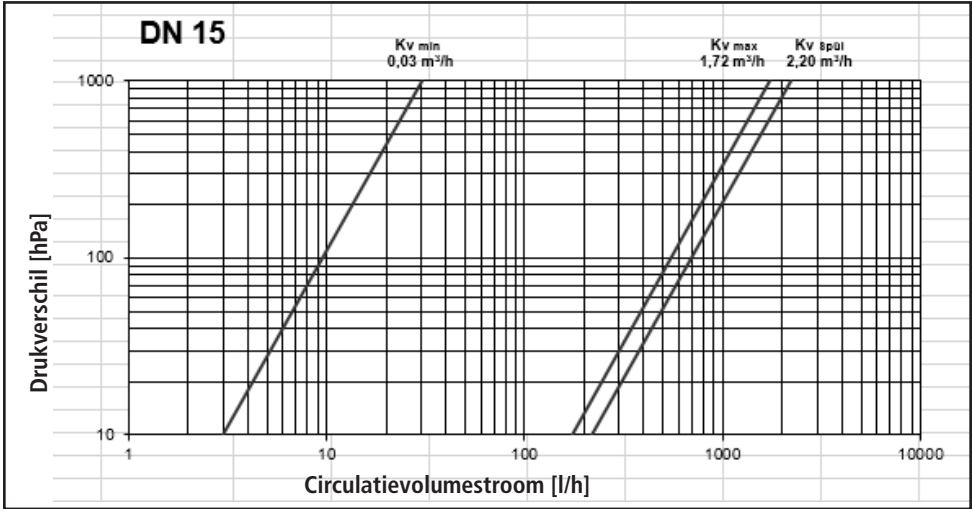

# 4

## Montage

1



Opmerking!  
Storingsdimensies  
aanhouden!

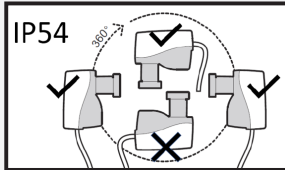

96 mm

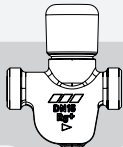

113 mm



70 mm

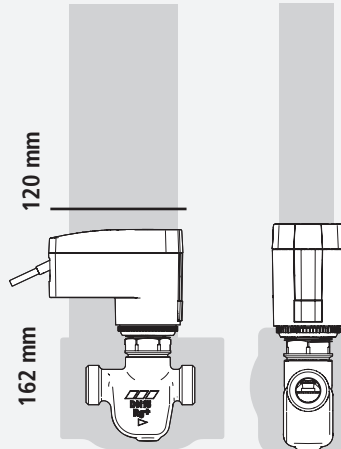

113 mm

70 mm

2

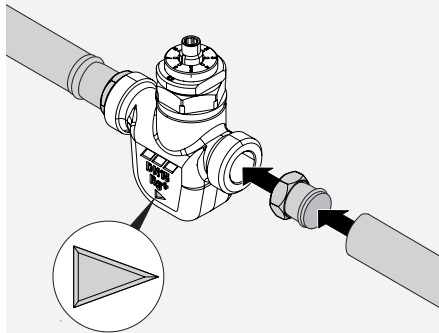

Opmerking!  
Houd rekening met de  
stroomrichting! In rechte  
leidingbuis aanbrengen!

3



Opmerking!  
De volgende stappen gelden  
voor de uitvoeringen 615 2G  
en 616 2G.

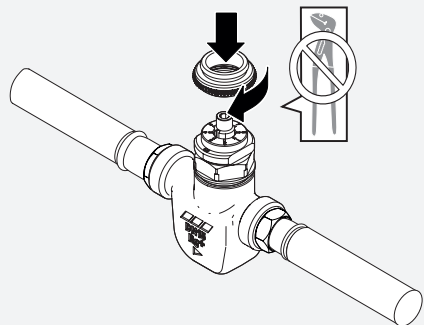

4

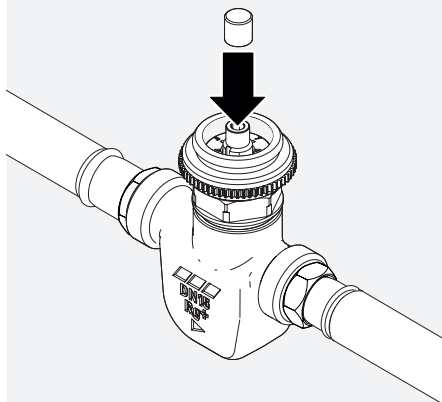

**Opmerking!**  
Een reserveverlengkap is in de leveringsomvang aanwezig.

5

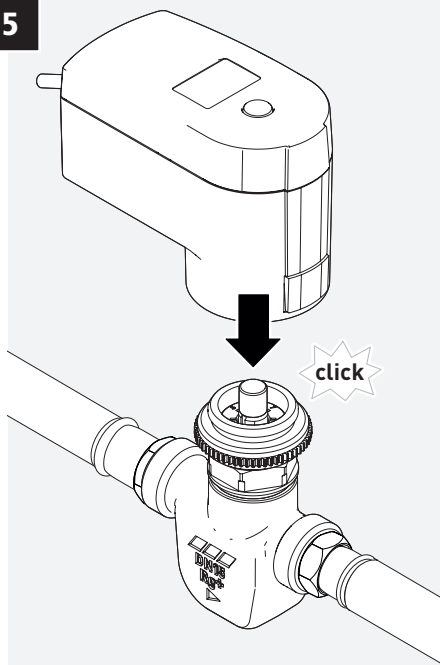

6

Fig. 615 2G (24V-uitvoering)

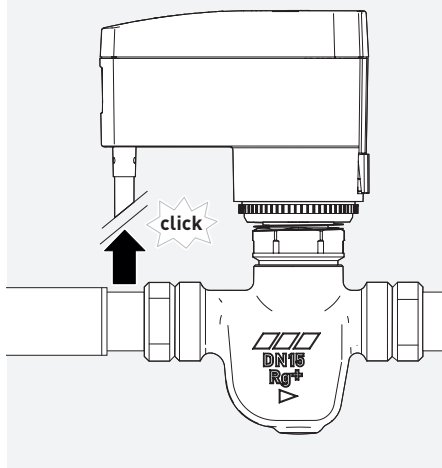

7

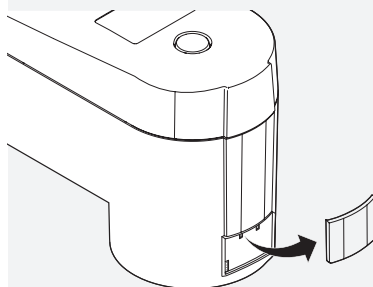

**Opmerking!**  
Het verwijderen van de vergrendelingstoets beschermt tegen demontage door onbevoegden.

# 5

## Elektrische aansluiting 230 V

1



**Gevaar!**

Elektr. stroom! Houd de omgeving droog!  
Spanningsvrij schakelen voordat u de behuizing opent!



**Opmerking!**

Fig. 615 2G en fig. 615 02 kunnen alleen worden ingeleerd met de MASTER 2.1 apparaatsoftware hoger dan V2.23.15. Bovendien moet het bijbehorende ventieltype „KHS CoolFlow V2.0“ worden geconfigureerd!



**Aansluiting 230V:**  
Fig. 686 02 008

[1] → br (BN)  
[2] → sw (SW)  
[3] → gr (GR)

**Opmerking! Aansluiting 230 V alleen in combinatie met KHS mini-systeembesturing MASTER 2.1 resp. KHS mini-systeembesturing SLAVE.**



**Opmerking!**

De aanvoerleiding naar de aandrijving moet ter plaatse voldoende ontstoord worden.

De besturing van de 230V 3-punts servomotor gebeurt via de KHS Mini-systeembesturing MASTER 2.1. Voor de installatie van een 230V-installatie worden volgende kabels aanbevolen:

- Ommantelde kabel: NYM 5x1,5mm<sup>2</sup>
- Platte stroomkabel: NYIF 5x1,5mm<sup>2</sup>

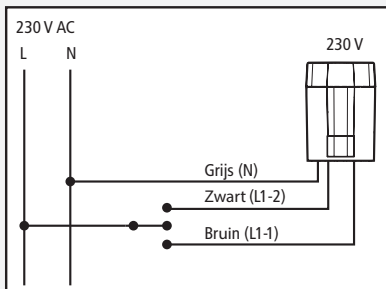

Functie	Beschrijving
Grijs (N)	Nuldraad
Spanning aan zwart (L1-2)	Ventieldrukplaat schuift in
Spanning aan bruin (L1-2)	Ventieldrukplaat schuift uit
Geen spanning aan bruin en zwart	Ventieldrukplaat blijft in de huidige positie

## 1

**Initialisatie:**

Na het inschakelen van de voedingsspanning voert de KHS CoolFlow koudwaterinregelafsluiter fig. 616 2G een proportionele initialisatie uit. Tijdens de initialisatiefase bepaalt de servomotor het bewegingstraject en geeft hierbij op het display „In” (voor initialisatie) weer. Tegelijkertijd knippert de groene led.

Eerst wordt de ventieldrukplaat volledig ingetrokken, waardoor de binnenste eindaanslag van de aandrijving wordt bepaald. Vervolgens schuift de ventieldrukplaat uit en bepaalt onderweg eerst de contactpositie met de ventielstoter en de tweede eindaanslag wanneer het einde van de ventielslag is bereikt en de servomotor tot stilstand is gekomen.

Het einde van de initialisatie wordt aangegeven door het uitgaan van de groene led, „In” op het display gaat uit en de afwisselende weergave van de aanwezige stuurspanning en de actuele instelpositie verschijnt.

**Opmerking!**

Voor een initialisatiefase heeft de KHS CoolFlow koudwaterinregelafsluiter fig. 616 2G proportioneel max. 7 min nodig. Tijdens de initialisatie reageert de servomotor niet op de toegepaste stuurspanning.

**Gebruik**

De 24V-servomotor wordt bestuurd via een 0 – 10 VDC-besturingssignaal van het gebouwbeheersysteem. Het besturingssignaal maakt een nauwkeurige regeling en positionering van de servomotor mogelijk. Als alternatief kan ook een PWM-signaal worden toegepast op de ingang voor de stuurspanning, zie diagram:

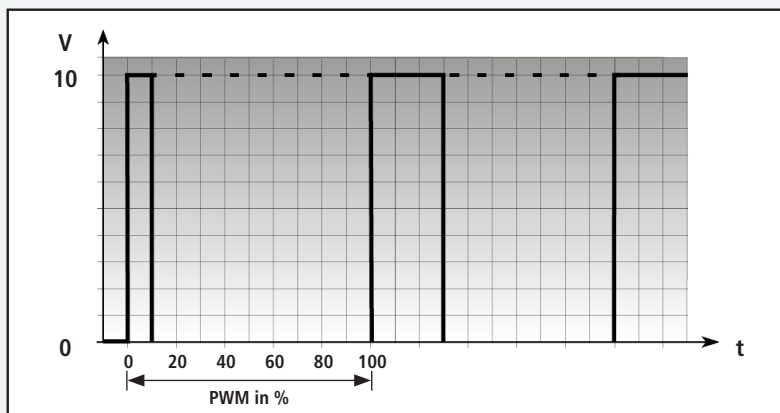

**Pulsbreedtefrequentie 100 Hz tot 1000 Hz**

Na initialisatie wordt de aanwezige stuurspanning proportioneel omgezet in een instelpositie. De aandrijving berekent uit stuurspanning, het ingestelde regeltraject of het gemeten verplaatsingstraject (afhankelijk van de modus) de in te nemen instelpositie en neemt deze positie precies in.

**Opmerking!**

- 0 V is volledige ventielstoter uitgeschoven
- 4,6 V ventielstoter in spoelstand
- 10 V is volledige ventielstoter ingeschoven

**Aansturing CoolFlow 24V-servomotor**

Functie	Spanning	Beschrijving
1 Regelfunctie	10 V	Afsluiter regelen
2 Spoelfunctie	4,6 V	Afsluiter spoelingen (+/- 0,5 V Kv-spoel)
3 Afsluitfunctie	0 V	Afsluiter gesloten

## 2

**Feedbacksignaal**

Het feedbacksignaal van de 24V-servomotor maakt via een 0 tot 10V-signaal een directe feedback van de actuele bedrijfstoestand aan de DDC-installatie mogelijk. Spanningen van 1 tot 9 volt geven informatie over de aandrijvingspositie, spanningen  $< 0,5$  V en  $> 9,5$  V signaleren fouten die zijn opgetreden. De aansluiting van het feedbacksignaal is spanningsbestendig tot 24 V.

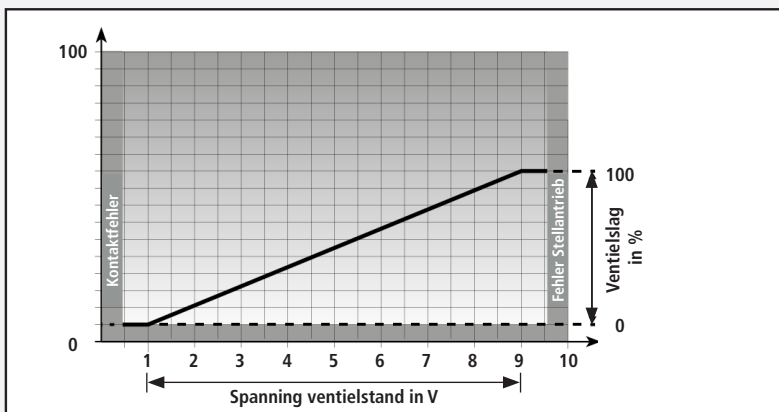

## Elektrische aansluiting 24V-servomotor AC/DC L1 (+) L2 (-)

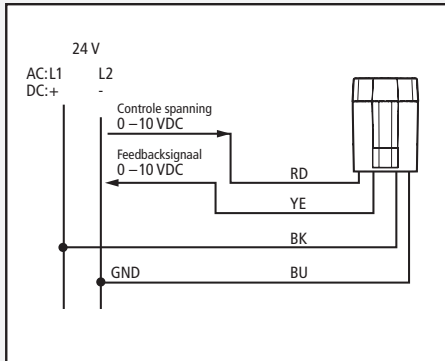

## Aansluitkabel

Voor de installatie van een 24V-installatie worden de volgende maximale kabellengtes aanbevolen:

Kabel	Doorsnede	Lengte
Standaard DCC-kabel	0,22 mm <sup>2</sup>	20 m
J-Y(ST)Y	0,8 mm <sup>2</sup>	45 m
NYM / NYIF	1,5 mm <sup>2</sup>	136 m

## Transformator/voeding

Er moet een veiligheidstransformator conform EN 61558-2-6 of een schakelende voeding conform EN 61558-2-16 worden gebruikt.

**Functie-indicaties via led**

Voor de functiesignalering van bedrijfstoestanden beschikt de Motoric Valve Drive: 230 V 3-Point servomotor over een meerkleurige led. Groen, oranje en rood worden gebruikt als signaalkleuren. Een signalering vindt alleen plaats als de servomotor wordt gevoed met bedrijfsspanning.

De led brandt ongeveer 3 seconden na het inschakelen om te voorkomen dat hij knippert tijdens de impulsaansturing.

Als de aandrijving tegen de bovenste of onderste aanslag loopt, schakelt de motor uit na een tijdsoverschrijding, net als de led.

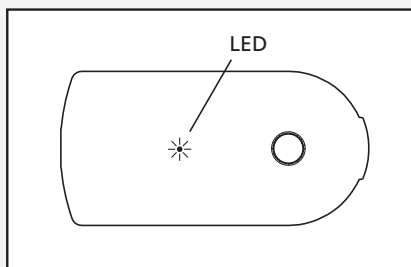

Ledsignaal	Betekenis
Rood	Fout
Groen	Ventieldrukplaat schuift in
Oranje	Ventieldrukplaat schuift uit

**Lcd-display | geldt alleen voor fig. 616 2G**

Het lcd-display van de 24V-servomotor geeft afwisselend de instelpositie en de aanwezige stuurspanning weer. Bij een regelverzoek wordt de actuele looprichting in het lcd-display door een pijl aangegeven. Bij een fout wordt de bijbehorende foutcode weergegeven en signaleerd door de permanent brandende rode led.

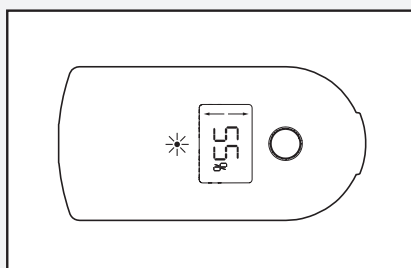

**Foutcodes | geldt alleen voor fig. 616 2G**

Fouten worden aangegeven met een foutcode. In de onderstaande tabel worden de verschillende foutcodes en foutcorrecties uitgelegd.

Foutcode	Beschrijving	Foutcorrectie
E7	Blokkering tijdens initialisatie-proces op niet toegestane positie	<ol style="list-style-type: none"> <li>1. Maak de servomotor spanningsloos.</li> <li>2. Beweeg de stelas met de handmatige afsteller uit de eindpositie.</li> <li>3. Herinitialisatie na het herinschakelen van de van de spanning. Neem contact op met de klantenservice als de fout herhaaldelijk optreedt.</li> </ol>
E8	Motorstroom te laag	<ol style="list-style-type: none"> <li>1. Herinitialisatie door de servomotor uit en in te schakelen.</li> <li>2. Als de fout na maximaal drie pogingen niet automatisch kon worden verholpen, moet u contact opnemen met de klantenservice.</li> </ol>
E9	Te lang lopen in één richting	<ol style="list-style-type: none"> <li>1. Herinitialisatie door de servomotor uit en in te schakelen.</li> <li>2. Als de fout na maximaal drie pogingen niet automatisch kon worden verholpen, moet u contact opnemen met de klantenservice.</li> </ol>

1



1. Druk op de vergrendelingstoets om te ontgrendelen

2

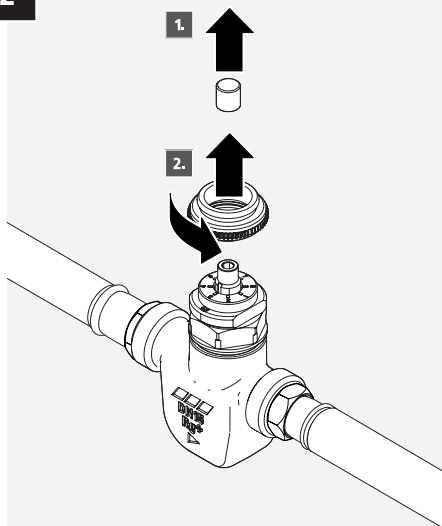

**Opmerking!**  
Controleer of de verlengkop nog gemonteerd is en verwijder deze.

3

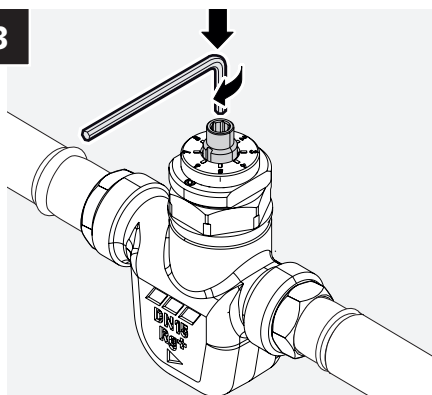

**Opmerking!**  
Handmatig afsluiten alleen wanneer deze is gemonteerd!



**Opmerking!**  
De spil moet bij de volgende opening helemaal tot aan de aanslag naar links gedraaid zijn, zodat de regelfunctie weer mogelijk is!

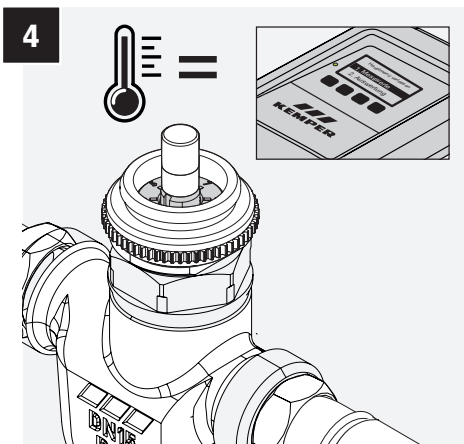
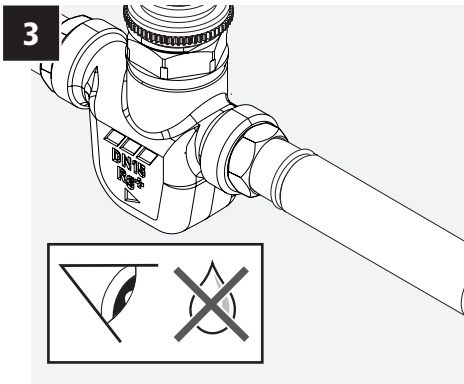
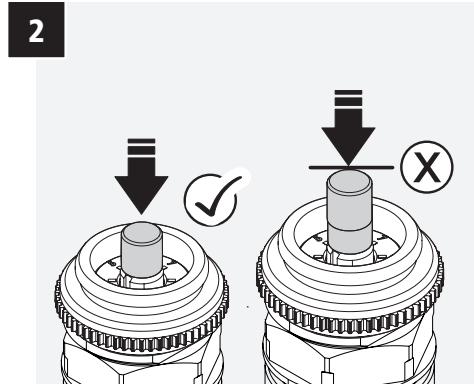
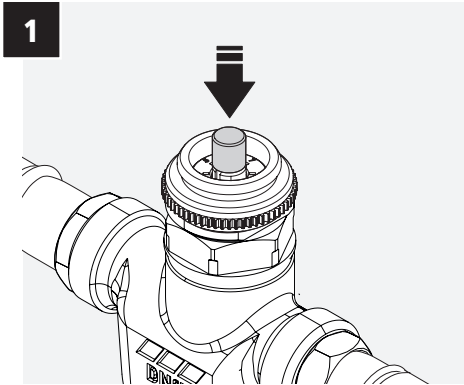

### Onderhoudsinterval

1x per jaar

#### 1-2: Afsluiter indrukken

Door het indrukken tijdens het bedrijf worden afzettingen losgemaakt en de afsluiter gereinigd.

#### 3: Visuele inspectie

Op lekkage controleren.

Bij lekkages afsluiter vervangen.

#### 4: Temperatuur controleren

Controleer de temperatuur bij de regelaar.

De temperaturen via het tappunt controleren.

#### Functietest

Reguleerfunctie, indien nodig de regel-, spoelen afsluitfunctie controleren.

#### Functiecontrole / hernieuwde initialisatie servomotor

Controle in gemonteerde toestand.

**Demontage**

1. Afsluiter evt. spanningsvrij schakelen.
2. Leidingen afsluiten.
3. Evt. servomotor demonteren.
4. Draai de schroefverbindingen los en haal de afsluiter van de leidingen.

**Afvalverwijdering**

Neem de plaatselijke voorschriften voor het recyclen en verwijderen van afval in acht.

Het product mag niet met het gewone huisvuil, maar moet vak-kundig worden afgevoerd.

Bestelnr.	Reservedelen en toebehoren
4712701500	Isolatieschaal (optioneel onderdeel)
6150000100	Servomotor 230 V (reservedeel)
6150200100	Servomotor 230 V (Nieuw reserveonderdeel)
6160000100	Servomotor 24 V (reservedeel)
6160200100	Servomotor 24 V (Nieuw reserveonderdeel)
6170G01500	KHS CoolFlow Koudwater-inregelafsluiter zonder servomotor

**Geschikte ventieladapter**

Fabrikantspecificatie van Kemper voor de fig. 615 2G | 616 2G.

Ventieladapter VA 80 - M30 x 1,5 8,5 mm

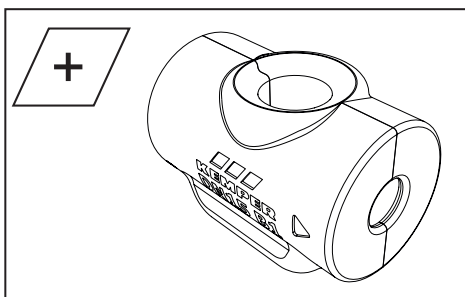
**Isolatieschaal**

Als optie is een isolatieschaal ter voorkoming van energieverlies, condensvorming en schimmel- en bacterievorming beschikbaar.

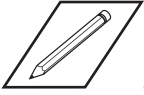

---

---



---

---

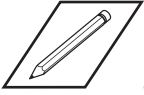

---

---



**KEMPER**

DRIVING PROGRESS

**Gebr. Kemper GmbH + Co. KG**  
Harkortstraße 5  
D-57462 Olpe

Service-Hotline +49 2761 891-800  
[www.kemper-group.com](http://www.kemper-group.com)  
[info@kemper-group.com](mailto:info@kemper-group.com)

